



Piping & Containment Systems Service Station Hardware

Global Product Catalogue
Effective April 2, 2012



Overview	5
The Total System Solution	6
UPP Piping System	8
UPP 32mm 1" Lined Electrical Conduit	10
UPP 32mm 1" Primary Pipe System	12
UPP 40x32mm 1" Secondary Containment Pipe System	14
UPP 50mm 1½" Primary Pipe System	16
UPP 63x50mm 1½" Secondary Containment Pipe System	20
UPP 63mm 2" Primary Pipe System	22
UPP 75x63mm 2" Secondary Containment Pipe System	26
UPP 90mm 3" Primary Pipe System	29
UPP 110x90mm Gemini Secondary Containment Pipe System	33
UPP 160x90mm 3" Secondary Containment Pipe System	34
UPP 110mm 4" Primary Pipe System	36
UPP 125x110mm Gemini Secondary Containment Pipe System	40
UPP 160x110mm 4" Secondary Containment Pipe System	41
UPP 160mm 6" Primary Pipe System	42
UPP 110mm 4" Duct System	44
APT Flexible Entry Boots & UPP Fusion Entry Seals	45
Fibreglass Entry Seals and Tools	49
Tank Access Chambers	50
Optimum Fusion Chambers	52
Leak Detection Equipment	53
Under Dispenser Containment Sumps	54
EBW Shear Valves	59
EBW Spill Containers	61
EBW Vapour Recovery Equipment	65
EBW Fill Point Equipment	66
Tank Access Covers	67
Monitoring Well Equipment	70
Aboveground Tank Equipment	71
Breakaways & Check Valves	72
AutoLimiter OPV	73
UPP Welders and Tools	75
Chamber & Sump Vacuum Test Kit	76
UPP Welders and Tools	79
Technical Information	80
Electrofusion Safety	84
Weld Pin Protection Caps	85
Contact Information	86

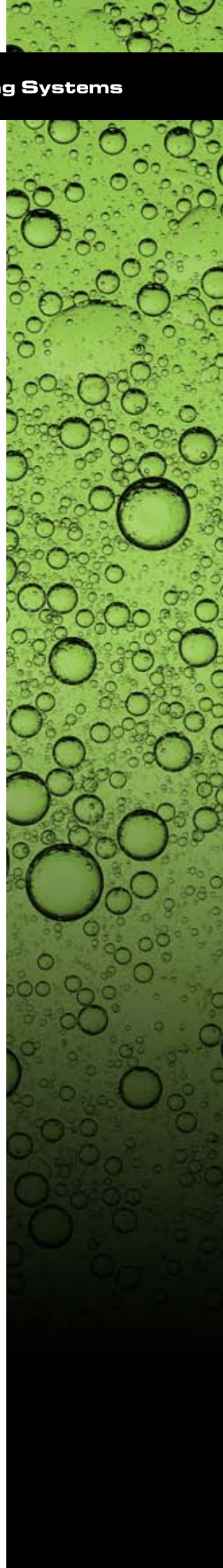

Piping & Containment Systems Service Station Hardware

With the most comprehensive product offering from an industry's leader in total system solutions, Franklin Fueling Systems provides unparalleled simplicity in placing one order, having one point of contact, with a customer-focused service team and receiving one consolidated shipment.

A wide variety of products, a world-class customer service experience and extensive technical background create a complete system solution where our services, features and products set us apart as an industry leader.

Complete Solution

Whether you want to automate your station or network, build or re-build your station according to the latest environmental laws, update a station to fulfil new regulations or intend to realise a more cost efficient site construction and operation, you can rely on Franklin Fueling Systems. Our submersible pumping systems, service station hardware, fuel management systems and complete pipework solutions can increase your efficiency and improve your business. In addition to the industry's most comprehensive product offering.

Franklin Fueling Systems also provides:

- One ordering point for all equipment.
- Factory tested leak-tight equipment.
- Reduced site downtimes.
- 100% Bio-fuel compatible options.
- Effective control of your fuel stocks.
- Assured environmental protection.
- Solutions to keep fuel in and water out.
- Lowest total cost of ownership
- Time and money savings.

Franklin Fueling Systems can deliver a complete package of pipework, manway chambers, under dispenser containment, submersible pumps and intelligent fuel stock & environmental monitoring systems all designed around your exact needs and delivered in one shipment, ready for installation.

Piping & Containment

Piping & Containment Systems consists of the industry's most complete line of underground and above ground containment products including piping, fittings, sumps and boots. Franklin Fueling Systems is able to provide piping solutions for diverse site needs with the most installer-friendly, semi-rigid piping systems on the market. Whether you require product or vent/vapour piping, Franklin has the solution to fit any scenario and when you monitor your piping & storage system using a Franklin fuel management system, you are covered by an upgraded warranty.

Service Station Hardware

Service Station Hardware is one of the most comprehensive lines of fuel station hardware available in the industry. Select all the tank trim accessories you could possibly need from one source, including complete lines of both aboveground and underground hardware. Each component offers unique benefits with a proven track record of performance and reliability.



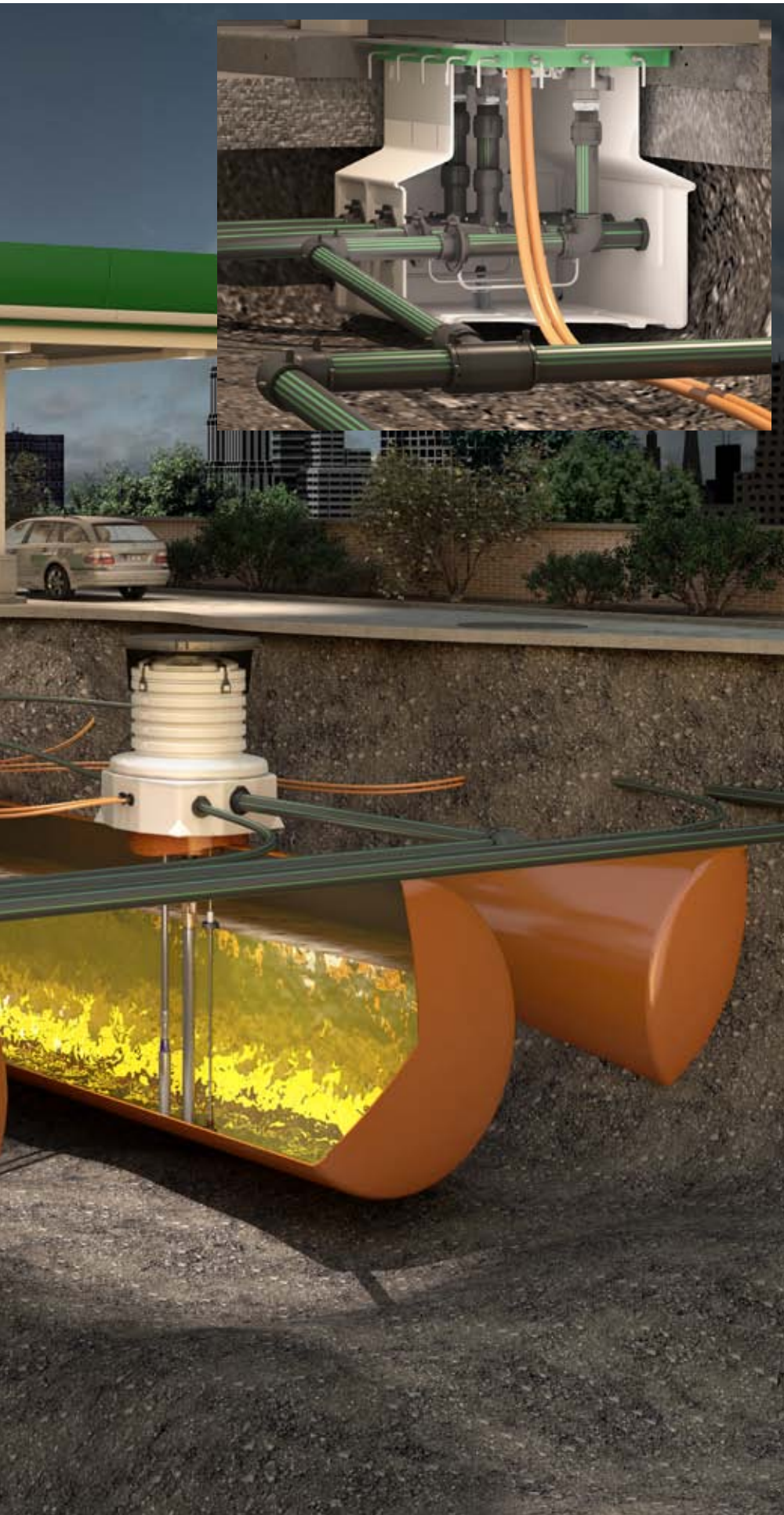

Piping and Containment

Franklin Fueling Systems offers the most comprehensive line of piping and containment products in the industry. The UPP brand features innovative technology and outstanding quality. With 30 years' worth of installations and a 100% leak-free performance record, Franklin Fueling Systems is the leading provider of fuel pipe.

Service Station Hardware

Franklin Fueling Systems fuel station hardware products comprise a comprehensive and environmentally friendly system, including a complete biofuel approved system for E85 and biodiesel sold under the brands EBW and Phil-Tite.

Submersible Pumping Systems

Franklin Fueling Systems submersible pumping systems provide faster fuel dispensing, improved efficiency and unmatched reliability. The FE Petro brand industry-leading product design offers the highest performing submersible pumping systems available.

Fuel Management Systems

Franklin Fueling Systems offers a complete line of inventory monitoring systems, providing users the capability to take complete control of fuel management. The complete range is ideal for monitoring inventory, environmental control and fuel management. Next generation technology from INCON allows users to monitor tanks from any web browser.

Dispensing Systems

Franklin Fueling Systems manufactures and markets a complete line of Stage II vapour recovery systems globally under the Healy product brand. Healy vapour recovery products suit any application and customize to any site, ensuring proper connection.

Transport Systems

Franklin Fueling Systems road tanker systems products make it easy to connect to loading terminals and underground storage tanks with our broad line of adapters, elbows and valves. Sold under the brand EBW, these products cover both loading and off-loading applications. Our road tanker hardware products provide a wide range of connection options.

UPP Primary Pipework

A Large Margin of Safety

The primary pipe system allows for the safe transport of fuel within a fuel delivery system and a principal function of this is to connect all key components of the delivery, storage and dispensing facilities. Pipe systems consist of the lined primary pipe, pipe fittings and transition fittings. The pipe itself is flexible and can be curved for gradual bends, although where immediate changes of direction or branches are required then elbow or tee fittings are available.

Pipework is installed through electrofusion entry seals, which weld the pipe to the sump and eliminate any leak paths providing one homogeneous construction from the underground tank access chamber to the dispenser connection. This ensures full protection from ingress of ground water and eliminates any chance of leakage to the environment.

UPP primary pipe is approved by all major approvals bodies around the world and has been installed in over 160 countries. Compatibility with a wide range of fuels, alcohol mixtures and additives has been proven during third party testing to ensure suitability for all fuel groups encountered around the world (refer to Page 80).

New EVOH Layer

Its strength advantages are as clear as the natural EVOH resin inner liner found in Franklin Fueling System's new UPP EN14125 Standard Pipe. This latest evolution in fuel piping features an innovative clear inner lining made of natural EVOH resin; a feature which allows UPP EN14125 standard pipe to achieve an exceptional Class T1 temperature rating. Class T1 strength means reliability and performance as UPP EN14125 Standard Pipe is rated for use in temperatures ranging from -40°C to +50°C.

The latest in co-extrusion technology allows us to permanently bond the clear un-pigmented, natural EVOH resin fuel contact layer seamlessly with a rugged PE100 high-density polyethylene outer structural layer, providing users with a new level of protection, performance and dependability.



Primary Pipe Advantages

- Due to its impressive T1 rating, the EN14125 Standard UPP pipe maintains a very high level of safety with operational temperature range of -40°C to +50°C, almost zero permeation and a burst pressure capability in excess of 40 bar.
- No requirement for a concrete trench because HDPE is structurally resistant to weight of backfill material and dynamic traffic loads.
- Non-conductive pipe cannot be a source of spark ignition and is therefore a safe choice concerning the risks of electrostatic discharge.
- UPP pipe is available in straight lengths or coils.
- Complete range of fittings is available.
- EN14125 and UL971 approved.

Bar Pressure	10 bar
Vacuum rating	-0.9 bar
Temperature Range	-40°C to +50°C

Electrofusion

At the heart of UPP pipework is a highly efficient electrofusion welding process which connects pipe and fittings to create a seamless direct burial pipework system. The welding operation uses the UPP's lightweight portable electrofusion welding unit to form the strongest of assemblies which is easily and quickly carried out, even in confined spaces and under any climatic conditions.

The UPP electrofusion welding process is safe and simple to complete; the welding unit calculates the exact energy level required to make a good joint every time regardless of the size or temperature of the fittings, and without the user needing to input any information. When the simple installation procedures are followed correctly the security and integrity of a watertight installation will remain for the lifetime of the site and provide unmatched resistance to ground movement or to seismic activity.



Secondary Pipe Advantages

- Co-axial sleeve pipe co-extruded over UPP Extra lined primary pipe.
- Uninterrupted interstitial space between the primary and secondary pipe.
- Leak detection system available.
- Full range of secondary containment fittings (5 bar rated).
- Pipe has passed testing to EN14125, temperature class T1 from -40°C to +50°C.
- EN14125 and UL971 approved.

Bar Pressure	5 bar
Vacuum rating	-0.6 bar
Temperature Range	-40°C to +50°C

UPP Secondary Contained Pipework

A Further Level of Safety

Where legislation requires, a further level of protection can be provided by using UPP secondary containment pipework. Secondary containment of the primary pipework is achieved using an outer pipe and the electrofusion process to make joints; providing a second barrier, also with no joints or leak paths.

Secondary pipe is terminated or closed onto the primary pipe using terminating reducers and this is completed at each end of a pipe run before making the transition to steel on the primary pipe work. The electrofusion principles are the same for both primary and secondary systems.

Secondary containment pipework has a 5 bar pressure and -0.6 bar vacuum rating which, when installed correctly following the simple installation procedures, is maintained for the full lifetime of the site. A very high level of safety is achieved from near zero permeation, a burst pressure capability in excess of 20 bar and an operational temperature range of -40°C to +50°C. The interstitial space between primary and secondary pipe can be monitored using pressure or vacuum leak detection monitoring systems.

Technical Services & Support

Bill of Materials, certified training, site piping design and layout assistance also play an important part of providing a complete solution for our customers. Franklin Fueling Systems owns the tools necessary for the manufacture of the UPP system. Our UL971 and EN14125 approved product range is created by our in-house design teams, developed to our specification, tested and approved in conjunction with relevant third parties and regular customer liaison sessions.

Approvals

UPP pipework system has received a large number of approvals from worldwide authorities and environment agencies. UPP is available to EN14125, UL971, IP2 and Shell approvals - a standard of safety and quality we have maintained throughout its more than 30 year history.

- AS/NZS 2053.1.2001
- EN 14125
- IP1
- IP2
- ISBN 0 85293 164 6
- JFTOT
- NBR14722
- SIPC
- UL 971
- ULC/ORD-C971

UPP 32mm 1" Lined Electrical Conduit

The semi-flexible nature of the conduit means that it is easier to install in comparison to metal conduits.

Due to its non-corrodible nature, the UPP 32mm electrical conduit solves the problem of deteriorating steel armoured cable and metallic conduits. Cables inside the conduit are not affected by contaminants in the ground. Conduit runs are completely joint-free thanks to the UPP fusion welding system.

Employing the latest and ever improving production technologies, UPP electrical conduit is manufactured from the best quality high density polyethylene material using an extrusion process which provides a bore of exceptional smoothness. A tough, extremely smooth, specially formulated bonded liner, running its full length, enables UPP conduit to achieve near-zero permeation. This permeation barrier makes installation of wiring easy and eliminates the need to use draw wires as the electrical wiring can easily be pushed through the smooth bore of the pipe. The UPP patented permeation barrier protects wiring from the ingress of any products. The day-glow orange colour makes it easy to identify, a must due to the sensitive nature of live fuel sites.

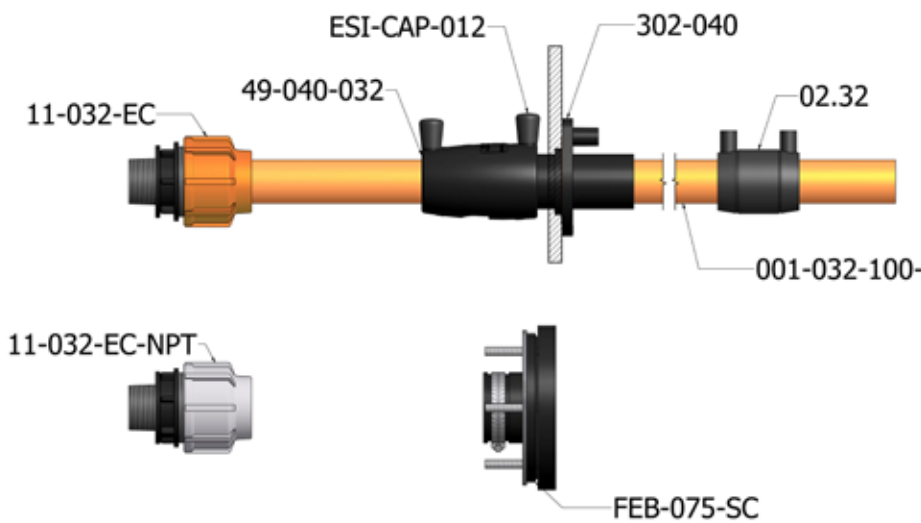

Advantages

- Approved by ERA to AS/NZS 2053.1.2001.
- Corrosion resistant.
- Electrofusion welding system.
- A complete range of fittings.
- Day-glow orange for maximum visibility.
- 25mm internal bore.



Description	Product Code	Unit	Weight (kg/m)	Weight (lbs/ft)	Diameter Ø (mm)
UPP Elect. Conduit Orange 32mm 100M	001-032-100-EC-E	100m	0.29	0.19	32



Description	Product Code	Pack Size	Weight (kg)	Weight (lbs)	Diameter Ø (mm)
UPP Fusion Coupler 32mm	02.32	50	0.06	0.13	32



Description	Product Code	Pack Size	Weight (kg)	Weight (lbs)	Diameter Ø (mm)
UPP Fusion Reducer 40x32mm Secondary	49-040-032	50	0.06	0.13	40/32



Description	Product Code	Pack Size	Weight (kg)	Weight (lbs)	Diameter Ø (mm)
UPP Fusion Seal 40mm	302-040	45	0.1	0.22	40



Description	Product Code	Pack Size	Weight (kg)	Weight (lbs)
Weld Pin Protection Cap	ESI-CAP-012	100	0.004	0.01



Description	Product Code	Pack Size	Weight (kg)	Weight (lbs)	Diameter Ø (mm)
UPP Termination 32mm 1" BSP Orange	11-032-EC	25	0.106	0.23	32



Description	Product Code	Pack Size	Weight (kg)	Weight (lbs)	Diameter Ø (mm)
UPP Termination 32mm 1" NPT Grey	11-032-EC-NPT	25	0.106	0.23	32

Ancillary Items



Description	Product Code	Pack Size	Weight (kg)	Weight (lbs)
Electrical Draw Pit 24" x 24"	IPS-2424	1	11.8	26
Electrical Draw Pit 36" x 36"	IPS-3636	1	29.9	66

UPP 32mm 1" Primary Pipe System

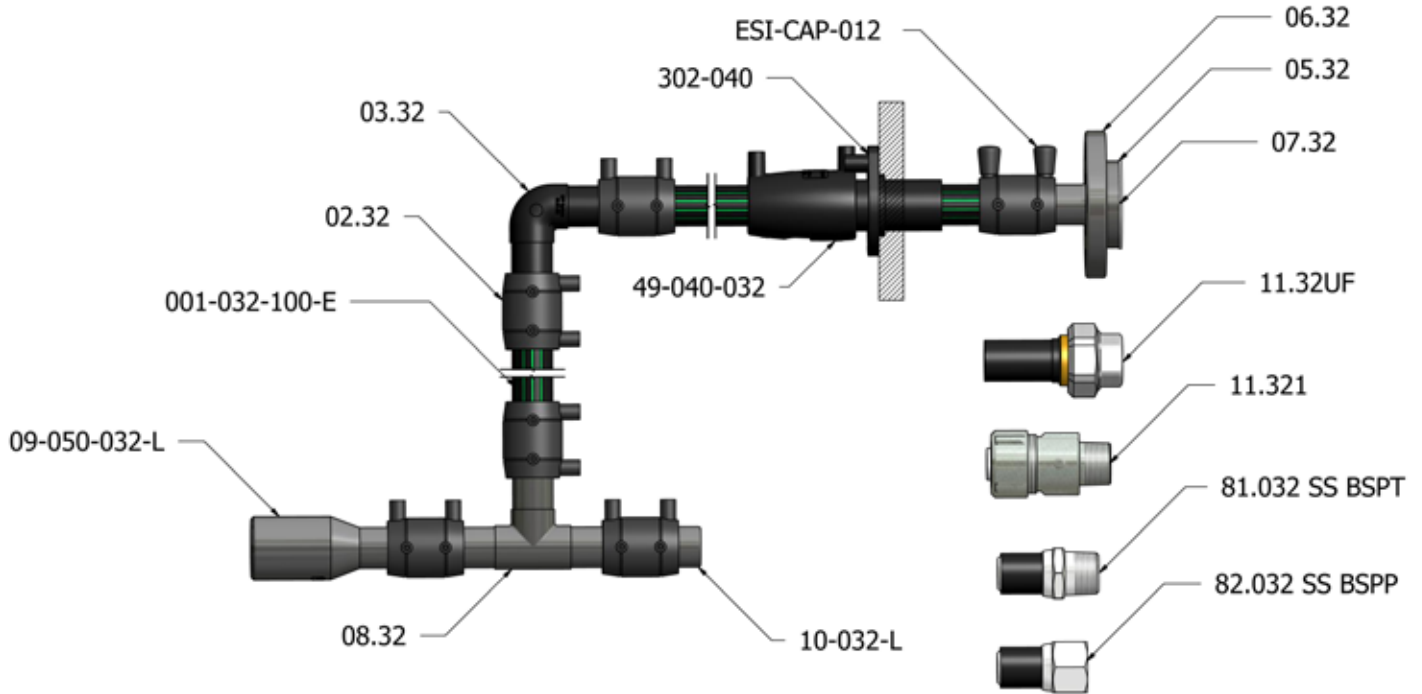

Description	Product Code	Unit	Weight (kg/m)	Weight (lbs/ft)	Diameter Ø (mm)
UPP Extra Pipe 32mm Coil 100M	001-032-100-E	100m	0.29	0.19	32

NOTE: Ideal for boiler house applications or small stand-by generators. OFTEC Listed. Also ideal for AdBlue.



Description	Product Code	Pack Size	Weight (kg)	Weight (lbs)	Diameter Ø (mm)
UPP Fusion Coupler 32mm	02.32	50	0.06	0.13	32



Description	Product Code	Pack Size	Weight (kg)	Weight (lbs)	Diameter Ø (mm)
UPP Plain Elbow 90° 32mm	03.32	40	0.06	0.13	32



Description	Product Code	Pack Size	Weight (kg)	Weight (lbs)	Diameter Ø (mm)
UPP Stub 32mm	05.32	50	0.06	0.13	32
UPP Flange Circular DN25 32mm	06.32	34	0.44	0.97	32
UPP Gasket 32mm for Stub	07.32	10	0.012	0.03	32

NOTE: ANSI version is available.





Description	Product Code	Pack Size	Weight (kg)	Weight (lbs)	Diameter Ø (mm)
UPP Tee Equal 32mm	08.32	20	0.08	0.18	32



Description	Product Code	Pack Size	Weight (kg)	Weight (lbs)	Diameter Ø (mm)
UPP Plain Reducer 50x32mm (pictured)	09-050-032-L	40	0.07	0.15	50/32
UPP Plain Reducer 63x32mm	09-063-032-L	28	0.11	0.24	63/32



Description	Product Code	Pack Size	Weight (kg)	Weight (lbs)	Diameter Ø (mm)
UPP End Cap 32mm	10-032-L	50	0.02	0.04	32



Description	Product Code	Pack Size	Weight (kg)	Weight (lbs)
Weld Pin Protection Cap	ESI-CAP-012	100	0.004	0.01



Description	Product Code	Pack Size	Weight (kg)	Weight (lbs)	Diameter Ø (mm)
UPP Union Termination 32mm x 1" BSP	11.32UF	20	0.34	0.75	32



Description	Product Code	Pack Size	Weight (kg)	Weight (lbs)	Diameter Ø (mm)
UPP Compression Termination 32mm x 1" BSP Male	11.321	25	0.42	0.93	32



Description	Product Code	Pack Size	Weight (kg)	Weight (lbs)	Diameter Ø (mm)
UPP SS Termination 32mm x 1" BSPT Male	81.032 SS BSPT	50	0.256	0.56	32



Description	Product Code	Pack Size	Weight (kg)	Weight (lbs)	Diameter Ø (mm)
UPP SS Termination 32mm x 1" BSPT Female	82.032 SS BSPT	50	0.25	0.55	32

UPP 40x32mm 1" Secondary Contained Pipe System

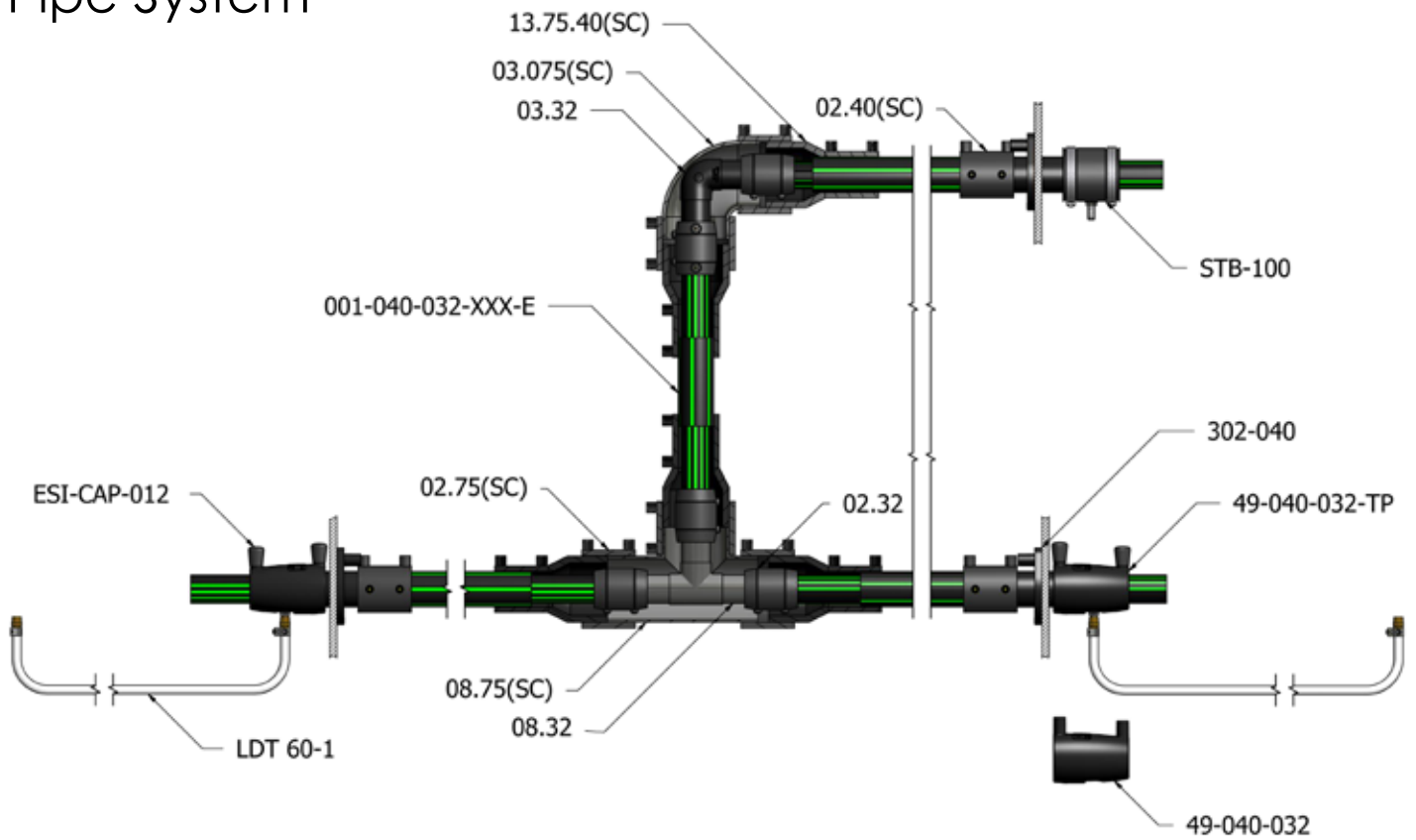

Description	Product Code	Pack Size	Weight (kg/m)	Weight (lbs/ft)	Diameter Ø (mm)
UPP Extra 32mm Coaxial Coil 50M	001-040-032-050-E	50m	0.64	0.43	40/32
UPP Coaxial Pipe 32mm Coil 100M	001-040-032-100-E	100m	0.64	0.43	40/32



Description	Product Code	Pack Size	Weight (kg)	Weight (lbs)	Diameter Ø (mm)
UPP Fusion Coupler 40mm Secondary	02.40(SC)	20	0.06	0.13	40



Description	Product Code	Pack Size	Weight (kg)	Weight (lbs)	Diameter Ø (mm)
UPP Fusion Coupler 75mm Secondary	02.75(SC)	20	0.11	0.24	75



Description	Product Code	Pack Size	Weight (kg)	Weight (lbs)	Diameter Ø (mm)
UPP Elbow 90° 75mm Secondary	03.75(SC)	40	0.12	0.26	75

NOTE: To contain the 03.32 90° Elbow



Description	Product Code	Pack Size	Weight (kg)	Weight (lbs)	Diameter Ø (mm)
UPP Tee Equal 75mm Secondary	08.75(SC)	20	0.14	0.31	75

NOTE: To contain the 08.32 Tee



Description	Product Code	Pack Size	Weight (kg)	Weight (lbs)	Diameter Ø (mm)
UPP Reducer 75x40mm Secondary	13.75.40(SC)	40	0.162	0.36	75/40



Description	Product Code	Pack Size	Weight (kg)	Weight (lbs)	Diameter Ø (mm)
UPP Fusion Reducer 40x32mm Secondary	49-040-032	50	0.06	0.13	40/32
UPP Fusion Reducer 40x32mm Sec with Test Port	49-040-032-TP-1	50	0.08	0.18	40/32

NOTE: Test Ports are 7mm Schrader valves with Protective Caps



Description	Product Code	Pack Size	Weight (kg)	Weight (lbs)	Diameter Ø (mm)
UPP Test Boof 40x32mm Secondary with Test Port	STB-100	1	0.2	0.5	40/32

NOTE: Test Ports are 7mm Schrader valves with Protective Caps



Description	Product Code	Pack Size	Weight (kg)	Weight (lbs)
Weld Pin Protection Cap	ESI-CAP-012	100	0.004	0.01

Ancillary Items



Description	Product Code	Pack Size	Weight (kg)	Weight (lbs)
Leak Detection Tube Kit - not for use with STB-100 product offering	LDT 60-1	1	0.05	0.11



Description	Product Code	Pack Size	Weight (kg)	Weight (lbs)
Leak Detection Tube Kit - for use with STB-100 product offering	BPT-200	1	0.05	0.11

Note: 32mm Primary Pipe System.
For Termination and Transition Fittings please refer to pages 12 to 13 and 43.

UPP 50mm 1½" Primary Pipe System

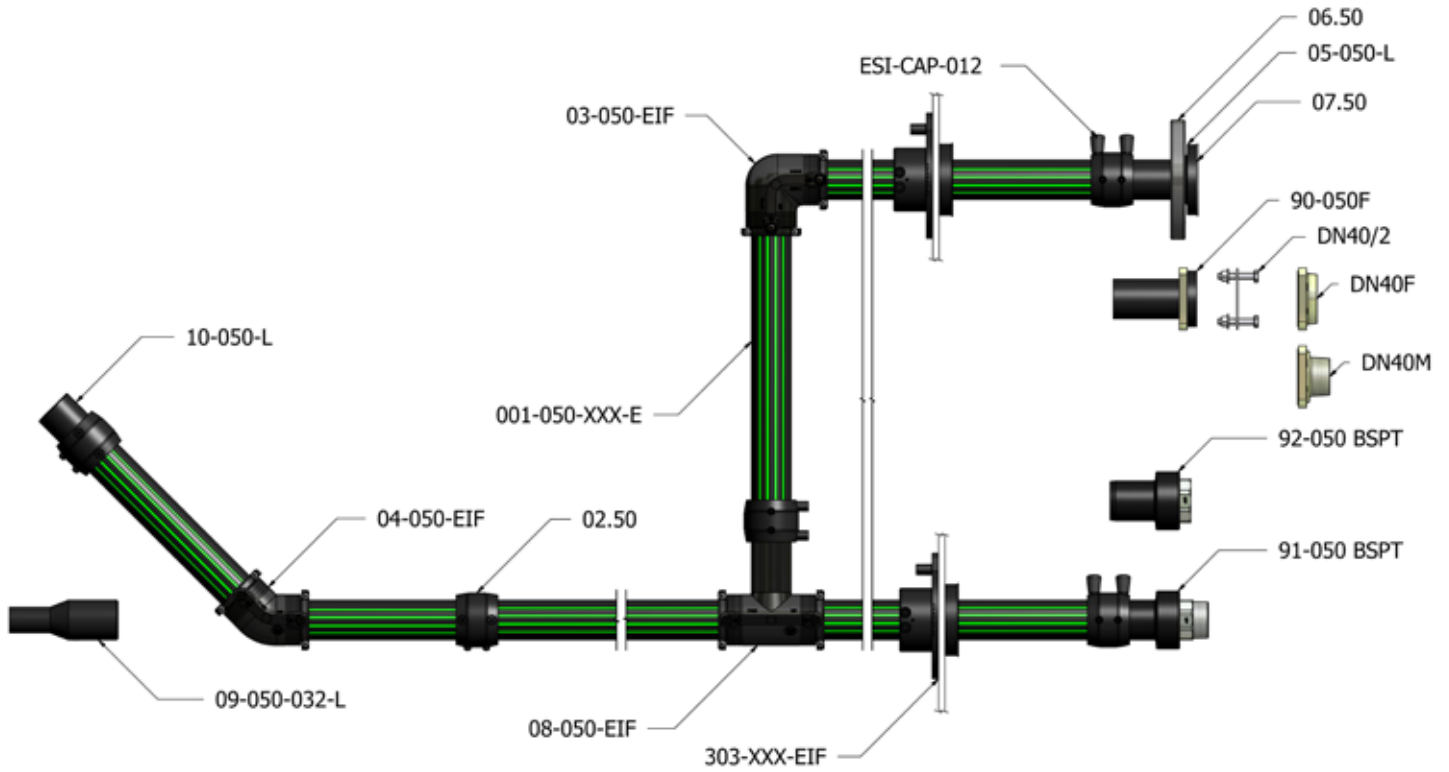

Description	Product Code	Unit	Weight (kg/m)	Weight (lbs/ft)	Diameter Ø (mm)
UPP Extra Pipe 50mm L=5.8M	001-050-006-E	696m	0.66	0.45	50
UPP Extra Pipe 50mm Coil 50M	001-050-050-E	50m	0.66	0.45	50
UPP Extra Pipe 50mm Coil 100M	001-050-100-E	100m	0.66	0.45	50



Description	Product Code	Pack Size	Weight (kg)	Weight (lbs)	Diameter Ø (mm)
UPP Fusion Coupler 50mm	02.50	20	0.08	0.18	50



Description	Product Code	Pack Size	Weight (kg)	Weight (lbs)	Diameter Ø (mm)
UPP Plain Elbow 90° 50mm	03-050-L	30	0.16	0.35	50



Description	Product Code	Pack Size	Weight (kg)	Weight (lbs)	Diameter Ø (mm)
UPP Electrofusion Elbow 90° 50mm	03-050-EIF	30	0.2	0.44	50



Description	Product Code	Pack Size	Weight (kg)	Weight (lbs)	Diameter Ø (mm)
UPP Plain Elbow 45° 50mm	04-050-L	22	0.13	0.29	50



Description	Product Code	Pack Size	Weight (kg)	Weight (lbs)	Diameter Ø (mm)
UPP Electrofusion Elbow 45° 50mm	04-050-EIF	22	0.13	0.29	50



Description	Product Code	Pack Size	Weight (kg)	Weight (lbs)	Diameter Ø (mm)
UPP Stub 50mm	05-050-L	50	0.12	0.26	50
UPP Flange Circular DN40 50mm	06.50	17	1.54	3.40	50
UPP Gasket 50mm for Stub	07.50	10	0.02	0.04	50



NOTE: ANSI version is available.



Description	Product Code	Pack Size	Weight (kg)	Weight (lbs)	Diameter Ø (mm)
UPP Plain Tee Equal 50mm	08-050-L	20	0.21	0.46	50



Description	Product Code	Pack Size	Weight (kg)	Weight (lbs)	Diameter Ø (mm)
UPP Electrofusion Tee 50mm	08-050-EIF	22	0.25	0.55	50



Description	Product Code	Pack Size	Weight (kg)	Weight (lbs)	Diameter Ø (mm)
UPP Plain Reducer 50x32mm	09-050-032-L	40	0.07	0.15	50/32
UPP Plain Reducer 63x50mm (pictured)	09-063-050-L	24	0.13	0.29	63/50
UPP Plain Reducer 90x50mm	09-090-050-L	15	0.29	0.64	90/50



Description	Product Code	Pack Size	Weight (kg)	Weight (lbs)	Diameter Ø (mm)
UPP Electrofusion Reducer 63x50mm	09-063-050-EIF	30	0.35	0.77	63/50



Description	Product Code	Pack Size	Weight (kg)	Weight (lbs)	Diameter Ø (mm)
UPP End Cap 50mm	10-050-L	30	0.05	0.11	50



Description	Product Code	Pack Size	Weight (kg)	Weight (lbs)
Weld Pin Protection Cap	ESI-CAP-012	100	0.004	0.01



Description	Product Code	Pack Size	Weight (kg)	Weight (lbs)	Diameter Ø (mm)
UPP Flanged Termination 50mm	90-050F	6	0.35	0.77	50
UPP Coupling Flange 1½" BSPT Male	DN40M	30	0.49	1.08	50
UPP Coupling Flange 1½" BSP Female	DN40F	30	0.418	0.92	50
UPP Gasket & Bolt Set for Coupling Flange DN 40	DN40/2	1	0.12	0.26	50



Description	Product Code	Pack Size	Weight (kg)	Weight (lbs)	Diameter Ø (mm)
UPP Termination 50mm x 1½" BSPT Male	91-050 BSPT	6	0.52	1.15	50
UPP Termination 50mm x 1½" NPT Male	91-050 NPT	6	0.52	1.15	50



Description	Product Code	Pack Size	Weight (kg)	Weight (lbs)	Diameter Ø (mm)
UPP Stainless Steel Termination 50mm x 1½" BSPT Male	81.050 SS BSPT	20	0.502	1.11	50



Description	Product Code	Pack Size	Weight (kg)	Weight (lbs)	Diameter Ø (mm)
UPP Termination 50mm x 1½" BSPT Female	92-050 BSPT	6	0.34	0.75	50
UPP Termination 50mm x 1½" NPT Female	92-050 NPT	6	0.34	0.75	50



Description	Product Code	Pack Size	Weight (kg)	Weight (lbs)	Diameter Ø (mm)
UPP Stainless Steel Termination 50mm x 1½" BSPT Female	82.050 SS BSPP	30	0.575	1.27	50



Description	Product Code	Pack Size	Weight (kg)	Weight (lbs)	Diameter Ø (mm)
UPP Union Termination 50mm x 1½" BSPT	92-050 U/F BSPT	6	0.61	1.34	50
UPP Union Termination 50mm x 1½" NPT	92-050 U/F NPT	6	0.61	1.34	50



Description	Product Code	Unit	Weight (kg)	Weight (lbs)	Diameter Ø (mm)
Pit Spanner 50A/F 91-050 For all Male 50mm sizes	91-050-TOOL	1	0.8	1.7	50
Pit Spanner 55A/F 92-050 For all Female 50mm sizes	92-050-TOOL	1	0.9	1.9	50



Description	Product Code	Pack Size	Weight (kg)	Weight (lbs)	Diameter Ø (mm)
Spare Gasket for 11.50UG	11.50G	10	0.004	0.01	50



Description	Product Code	Pack Size	Weight (kg)	Weight (lbs)	Diameter Ø (mm)
UPP Compression Termination 50mm x 1½" BSPT	11.501	10	1.02	2.25	50



Description	Product Code	Pack Size	Weight (kg)	Weight (lbs)	Diameter Ø (mm)
UPP Compression Elbow 50mm x 1½" BSP Female	11.503F	5	1.58	3.48	50



Description	Product Code	Pack Size	Weight (kg)	Weight (lbs)	Diameter Ø (mm)
UPP Compression Tee 50mm x 1½" BSP Female	11.505	5	2.5	5.51	50



Description	Product Code	Pack Size	Weight (kg)	Weight (lbs)	Diameter Ø (mm)
UPP Spare Olive for 11.50X	11.501.OL	10	0.02	0.04	50

Note: The Union and Compression Transitions are supplied as an assembly with the necessary gasket or olive

UPP 63x50mm 1½" Secondary Contained Pipe System

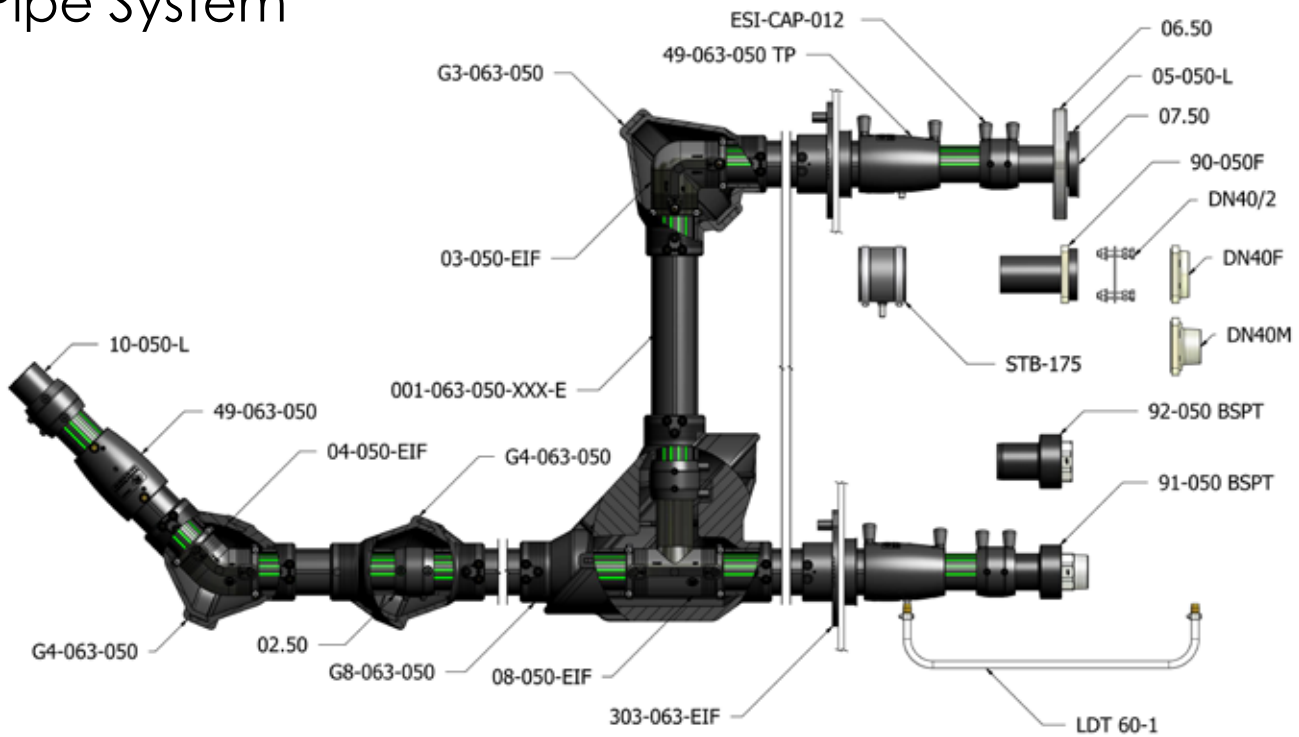

Description	Product Code	Pack Size	Weight (kg/m)	Weight (lbs/ft)	Diameter Ø (mm)
UPP Extra Coaxial Pipe 50mm Coil 30M	001-063-050-030-E	30m	1.17	0.78	63/50
UPP Extra Coaxial Pipe 50mm Coil 100M	001-063-050-100-E	100m	1.17	0.78	63/50



Description	Product Code	Pack Size	Weight (kg/m)	Weight (lbs/ft)	Diameter Ø (mm)
UPP Secondary Pipe 63mm L=5.8M	000-063-006-SC-E	408m	0.50	0.34	63



Description	Product Code	Pack Size	Weight (kg)	Weight (lbs)	Diameter Ø (mm)
SC 63x50mm UPP Gemini 90° Elbow	G3-063-050	8	0.77	1.69	63



Description	Product Code	Pack Size	Weight (kg)	Weight (lbs)	Diameter Ø (mm)
SC 63x50mm UPP Gemini 45° Elbow OR SC 63x50mm UPP Gemini Inline Joint	G4-063-050	8	0.63	2.64	63



Description	Product Code	Pack Size	Weight (kg)	Weight (lbs)	Diameter Ø (mm)
SC 63x50mm UPP Gemini Tee	G8-063-050	TBA	2.28	5.02	63



Description	Product Code	Pack Size	Weight (kg)	Weight (lbs)	Diameter Ø (mm)
UPP Fusion Coupler 63mm Secondary	02.63(SC)	20	0.1	0.22	63



Description	Product Code	Pack Size	Weight (kg)	Weight (lbs)	Diameter Ø (mm)
UPP Elbow 90° UPP 110mm Secondary	03.110(SC)	20	0.27	0.60	110

NOTE: To contain the 03-50-L 90° Elbow and the 03-050-EIF 90° Elbow.



Description	Product Code	Pack Size	Weight (kg)	Weight (lbs)	Diameter Ø (mm)
UPP Elbow 45° UPP 110mm Secondary	04.110(SC)	25	0.17	0.38	110

NOTE: To contain the 04-50-L 45° Elbow and the 04-050-EIF 90° Elbow.



Description	Product Code	Pack Size	Weight (kg)	Weight (lbs)	Diameter Ø (mm)
UPP Tee 110mm Secondary	08.110(SC)	15	0.376	0.83	110

NOTE: To contain the 08-50-L Tee and the 08-050-EIF Tee.



Description	Product Code	Pack Size	Weight (kg)	Weight (lbs)	Diameter Ø (mm)
UPP Fusion Reducer 63x50mm Secondary	49-063-050	45	0.18	0.40	63/50
UPP Fusion Reducer 63x50mm Secondary with Test Port	49-063-050-TP	45	0.2	0.44	63/50



Description	Product Code	Pack Size	Weight (kg)	Weight (lbs)	Diameter Ø (mm)
UPP Sliding Reducer 110x63mm Secondary	49-110-063(SC)	15	0.48	1.06	110/63



Description	Product Code	Pack Size	Weight (kg)	Weight (lbs)	Diameter Ø (mm)
UPP Test Boot 63x50mm Secondary with Test Port	STB-175	1	0.2	0.5	63/50

NOTE: Test Ports are 7mm Schrader valves with Protective Caps.



Description	Product Code	Pack Size	Weight (kg)	Weight (lbs)	Diameter Ø (mm)
UPP Fusion Seal 63mm with Integrated Coupler	303-063-EIF	20	0.24	0.53	63



Description	Product Code	Pack Size	Weight (kg)	Weight (lbs)
Weld Pin Protection Cap	ESI-CAP-012	100	0.004	0.01

Ancillary Items



Description	Product Code	Pack Size	Weight (kg)	Weight (lbs)
Leak Detection Tube Kit - not for use with STB-175 product offering	LDT 60-1	1	0.05	0.11



Description	Product Code	Pack Size	Weight (kg)	Weight (lbs)
Leak Detection Tube Kit - for use with STB-175 product offering	BPT-200	1	0.05	0.11

Note: 50mm Primary Pipe System.
For Termination and Transition Fittings please refer to pages 16 to 19.

UPP 63mm 2" Primary Pipe System

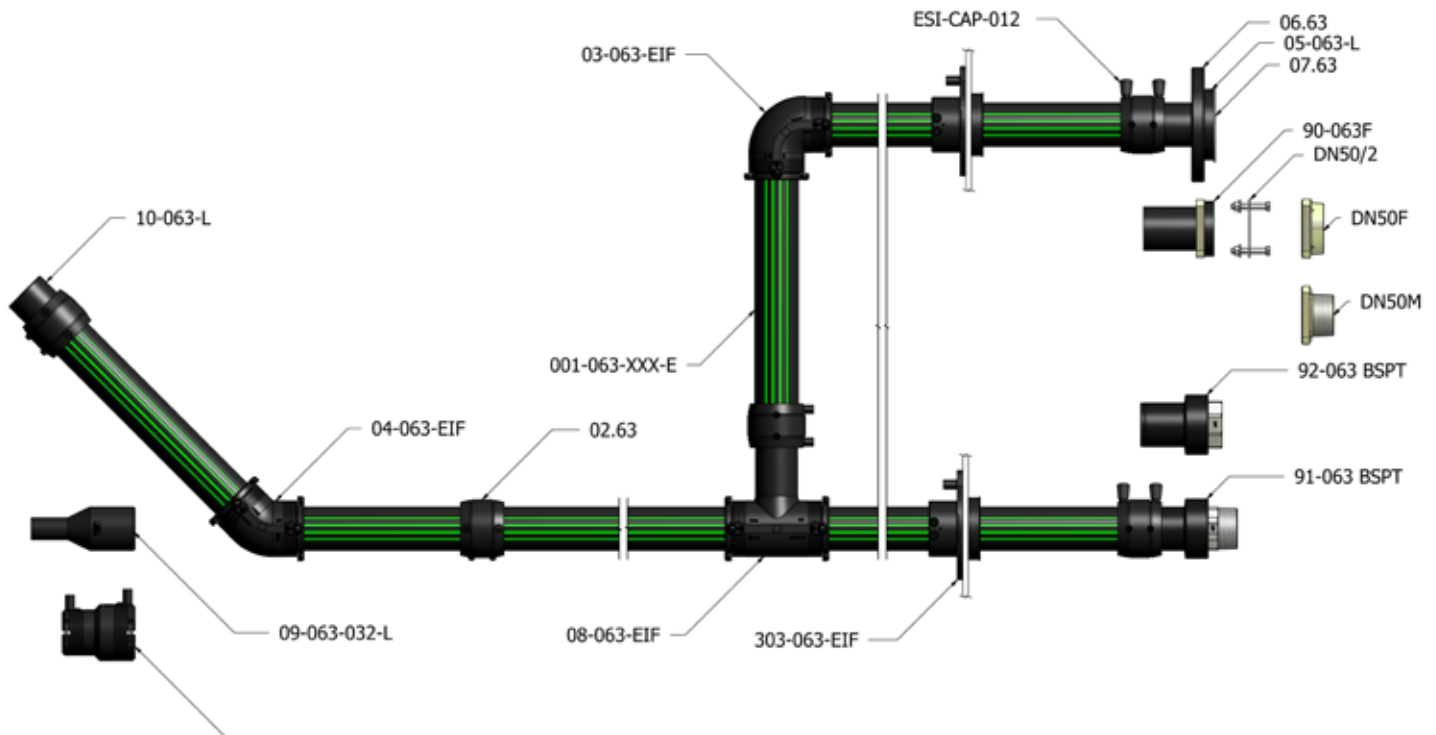

Description	Product Code	Pack Size	Weight (kg/m)	Weight (lbs/ft)	Diameter Ø (mm)
UPP Extra Pipe 63mm L=5.8M	001-063-006-E	408m	1.05	0.70	63
UPP Extra Pipe 63mm L=7.5M	001-063-007-E	408m	1.05	0.70	63
UPP Extra Pipe 63mm L=8M	001-063-008-E	544m	1.05	0.70	63
UPP Extra Pipe 63mm Coil=100M	001-063-100-E	100m	1.05	0.70	63



Description	Product Code	Pack Size	Weight (kg)	Weight (lbs)	Diameter Ø (mm)
UPP Fusion Coupler 63mm	02.63	25	0.12	0.26	63



Description	Product Code	Pack Size	Weight (kg)	Weight (lbs)	Diameter Ø (mm)
UPP Plain Elbow 90° 63mm	03-063-L	20	0.27	0.60	63



Description	Product Code	Pack Size	Weight (kg)	Weight (lbs)	Diameter Ø (mm)
UPP Electrofusion Elbow 90° 63mm	03-063-EIF	18	0.3	0.66	63



Description	Product Code	Pack Size	Weight (kg)	Weight (lbs)	Diameter Ø (mm)
UPP Plain Elbow 45° 63mm	04-063-L	50	0.22	0.49	63



Description	Product Code	Pack Size	Weight (kg)	Weight (lbs)	Diameter Ø (mm)
UPP Electrofusion Elbow 45° 63mm	04-063-EIF	24	0.25	0.55	63



Description	Product Code	Pack Size	Weight (kg)	Weight (lbs)	Diameter Ø (mm)
UPP Stub 63mm	05-063-L	30	0.18	0.40	63
UPP Flange Circular DN50 63mm	06.63	15	0.88	1.94	63
UPP Gasket 63mm for Stub	07.63	10	0.02	0.04	63



NOTE: ANSI version is available.



Description	Product Code	Pack Size	Weight (kg)	Weight (lbs)	Diameter Ø (mm)
UPP Plain Tee Equal 63mm	08-063-L	25	0.37	0.82	63



Description	Product Code	Pack Size	Weight (kg)	Weight (lbs)	Diameter Ø (mm)
UPP Electrofusion Tee 63mm	08-063-EIF	12	0.41	0.90	63



Description	Product Code	Pack Size	Weight (kg)	Weight (lbs)	Diameter Ø (mm)
UPP Reducing Tee 90x63mm	08-090-063-L	15	0.83	1.83	90
UPP Reducing Tee 110x63mm	08-110-063-L	10	1.27	2.80	110



Description	Product Code	Pack Size	Weight (kg)	Weight (lbs)	Diameter Ø (mm)
UPP Plain Reducer 63x32mm	09-063-032-L	15	0.29	0.64	90/50
UPP Plain Reducer 63x50mm	09-063-050-L	15	0.29	0.64	90/50
UPP Plain Reducer 90x63mm (pictured)	09-090-063-L	20	0.32	0.71	90/63
UPP Plain Reducer 110x63mm	09-110-063-L	30	0.35	0.77	110/63



Description	Product Code	Pack Size	Weight (kg)	Weight (lbs)	Diameter Ø (mm)
UPP Electrofusion Reducer 63x50mm	09-063-050-EIF	30	0.35	0.77	63/50
UPP Electrofusion Reducer 90x63mm (pictured)	09-090-063-EIF	30	0.35	0.77	90/63



Description	Product Code	Pack Size	Weight (kg)	Weight (lbs)	Diameter Ø (mm)
UPP End Cap 63mm	10-063-L	50	0.08	0.18	63



Description	Product Code	Pack Size	Weight (kg)	Weight (lbs)
Weld Pin Protection Cap	ESI-CAP-012	100	0.004	0.01



Description	Product Code	Pack Size	Weight (kg)	Weight (lbs)	Diameter Ø (mm)
O Ring for 12.63	12.63.ORING	1	0.002	0.004	63



Description	Product Code	Pack Size	Weight (kg)	Weight (lbs)	Diameter Ø (mm)
UPP Flanged Termination 63mm	90-063F	6	0.40	0.88	63
UPP Coupling Flange 2" BSPT Male	DN50M	25	0.66	1.46	2"
UPP Coupling Flange 2" NPT Male	DN50M NPT	40	0.634	1.40	2"
UPP Coupling Flange 2" BSP Female	DN50F	30	0.498	1.10	2"
UPP Gasket & Bolt Set for Coupling Flange DN 50	DN50/2	1	0.108	0.24	--



* Available on request.



Description	Product Code	Pack Size	Weight (kg)	Weight (lbs)	Diameter Ø (mm)
UPP Termination 63mm x 1 1/2" BSPT Male	91-063-1 BSPT	6	0.59	1.34	63
UPP Termination 63mm x 1 1/2" NPT Male	91-063-1 NPT	6	0.59	1.34	63



Description	Product Code	Pack Size	Weight (kg)	Weight (lbs)	Diameter Ø (mm)
UPP Termination 63mm x 2" BSPT Male	91-063 BSPT	6	0.7	1.54	63
UPP Termination 63mm x 2" NPT Male	91-063 NPT	6	0.7	1.54	63



Description	Product Code	Pack Size	Weight (kg)	Weight (lbs)	Diameter Ø (mm)
UPP SS Termination 63mm x 2" BSPT Male	81.063 SS BSPT	20	0.756	1.67	63



Description	Product Code	Pack Size	Weight (kg)	Weight (lbs)	Diameter Ø (mm)
UPP Termination 63mm x 1 1/2" BSPT Female	92-063-1 BSPT	6	0.42	0.93	63
UPP Termination 63mm x 1 1/2" NPT Female	92-063-1 NPT	6	0.42	0.93	63



Description	Product Code	Pack Size	Weight (kg)	Weight (lbs)	Diameter Ø (mm)
UPP Termination 63mm x 2" BSPT Female	92-063 BSPT	6	0.55	1.21	63
UPP Termination 63mm x 2" NPT Female	92-063 NPT	6	0.55	1.21	63



Description	Product Code	Pack Size	Weight (kg)	Weight (lbs)	Diameter Ø (mm)
UPP SS Termination 63mm x 2" BSPT Female	82.063 SS BSPP	20	0.785	1.73	63



Description	Product Code	Pack Size	Weight (kg)	Weight (lbs)	Diameter Ø (mm)
UPP Union Termination 63mm x 2" BSPT	92-063 UF BSPT	6	0.91	2.01	63
UPP Union Termination 63mm x 2" NPT	92-063UF NPT	6	0.91	2.01	63



Description	Product Code	Unit	Weight (kg)	Weight (lbs)	Diameter Ø (mm)
Plt Spanner 62A/F 91-063 For all Male 63mm sizes	91-063-TOOL	1	1.1	2.4	63
Plt Spanner 67A/F 92-063 For all Male 63mm sizes	92-063-TOOL	1	1.2	2.6	63



Description	Product Code	Pack Size	Weight (kg)	Weight (lbs)	Diameter Ø (mm)
Spare Gasket for 63UF fittings	11.63G	10	0.003	0.01	63



Description	Product Code	Unit	Weight (kg/m)	Weight (lbs/ft)	Material
Ball Valve 2" BSP F/F ½ Turn	BV(2)	1	1.99	4.39	Galvanised Steel

Note: The Union and Compression Transitions are supplied as an assembly with the necessary gasket or olive

UPP 75x63mm 2" Secondary Contained Pipe System

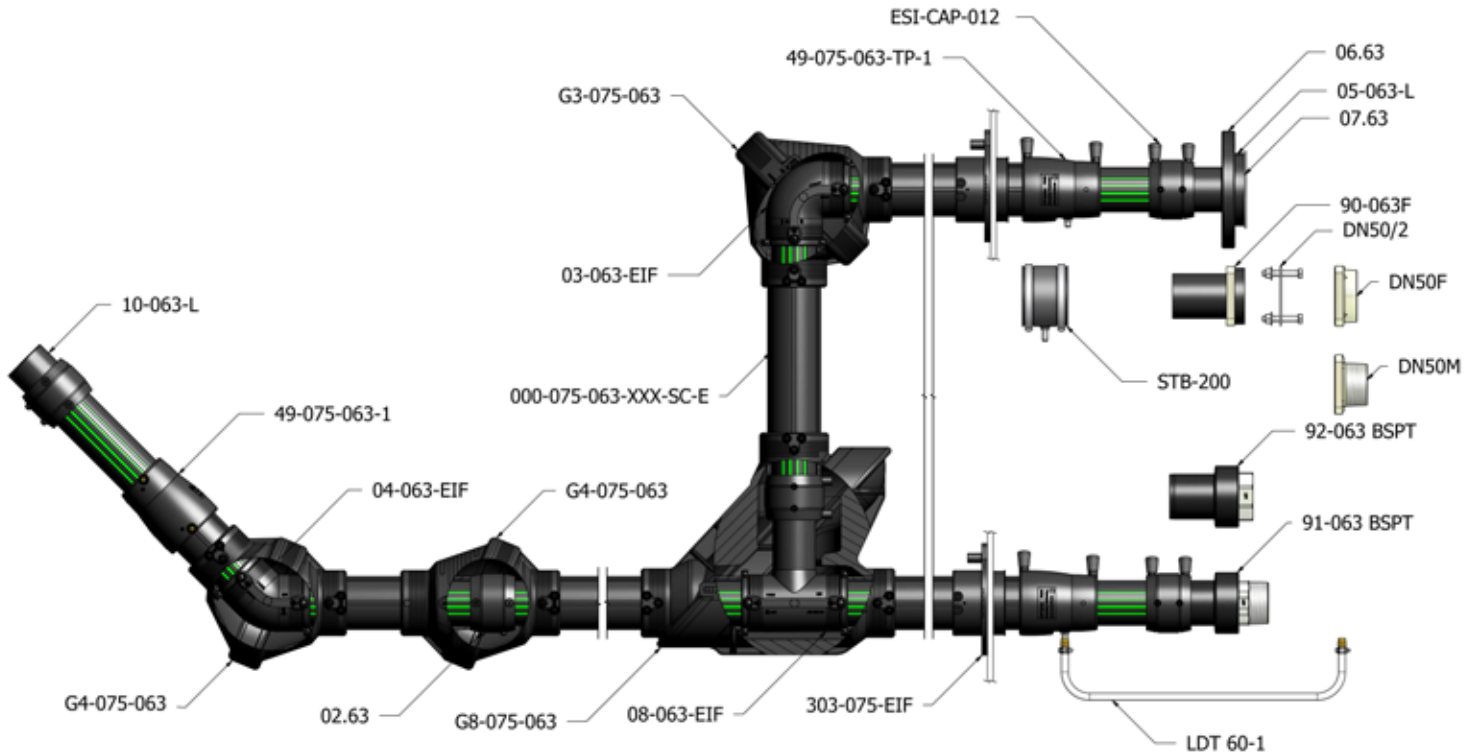

Description	Product Code	Pack Size	Weight (kg/m)	Weight (lbs/ft)	Diameter Ø (mm)
UPP Extra Coaxial Pipe 63mm L=10M	001-075-063-010-E	460m	1.72	1.15	75/63
UPP Extra Coaxial Pipe 63mm Coil 30M	001-075-063-030-E	30m	1.72	1.15	75/63
UPP Extra Coaxial Pipe 63mm Coil 50M	001-075-063-050-E	50m	1.72	1.15	75/63



Description	Product Code	Pack Size	Weight (kg/m)	Weight (lbs/ft)	Diameter Ø (mm)
UPP Secondary Pipe 75mm L=5.8M	000-075-006-SC-E	276m	0.67	0.45	75
UPP Secondary Pipe 75mm L=8M	000-075-008-SC-E	368m	0.67	0.45	75
UPP Secondary Pipe 110mm L=5.8M	000-110-006-SC-E	138m	1.46	0.98	110



Description	Product Code	Pack Size	Weight (kg)	Weight (lbs)	Diameter Ø (mm)
SC 75x63mm UPP Gemini 90° Elbow	G3-075-063	6	1.20	2.64	75



Description	Product Code	Pack Size	Weight (kg)	Weight (lbs)	Diameter Ø (mm)
SC 75x63mm UPP Gemini 45° Elbow OR SC 75x63mm UPP Gemini Inline Elbow	G4-075-063	6	0.93	2.08	75



Description	Product Code	Pack Size	Weight (kg)	Weight (lbs)	Diameter Ø (mm)
SC 75x63 UPP Gemini Tee	G8-075-063	2	2.98	6.65	75



Description	Product Code	Pack Size	Weight (kg)	Weight (lbs)	Diameter Ø (mm)
UPP Fusion Coupler 75mm Secondary (pictured)	02.75(SC)	20	0.11	0.24	75
UPP Fusion Coupler 110mm Secondary	02.110(SC)	35	0.17	0.37	110



Description	Product Code	Pack Size	Weight (kg)	Weight (lbs)	Diameter Ø (mm)
SC 110 x 63mm Bend 90° Elbow	03.110.63(SC)	15	0.64	1.41	110/63



Description	Product Code	Unit	Weight (kg)	Weight (lbs)	Diameter Ø (mm)
UPP Bend 90° 110x63mm Secondary Contained - Long	03.110.63(SC).L	1	1.36	3.00	110/63



Description	Product Code	Unit	Weight (kg)	Weight (lbs)	Diameter Ø (mm)
UPP Tee 110x63mm Secondary Contained - Long	08.110.63(SC).L	1	1.55	3.42	110/63



Description	Product Code	Pack Size	Weight (kg)	Weight (lbs)	Diameter Ø (mm)
UPP Reducer 110x75mm Secondary	09.110.75(SC)	15	0.1	0.22	110/75



Description	Product Code	Pack Size	Weight (kg)	Weight (lbs)	Diameter Ø (mm)
UPP End Cap 75mm Secondary	10-075-SC	20	0.11	0.24	75
UPP End Cap 110mm Secondary	10-110-SC	20	0.4	0.8	110



Description	Product Code	Pack Size	Weight (kg)	Weight (lbs)	Diameter Ø (mm)
UPP Fusion Reducer 75x63mm Secondary	49-075-063-1	25	0.2	0.44	75/63
UPP Fusion Reducer 75x63mm Secondary with Test Port	49-075-063-TP-1	25	0.22	0.49	75/63



Description	Product Code	Pack Size	Weight (kg)	Weight (lbs)	Diameter Ø (mm)
UPP Sliding Reducer 110x75mm Secondary	49-110-075(SC)	15	0.48	1.06	110/75



Description	Product Code	Pack Size	Weight (kg)	Weight (lbs)	Diameter Ø (mm)
UPP Test Boot 75x63mm Secondary with Test Port	STB-200	1	0.2	0.5	75/63

NOTE: Test Ports are 7mm Schrader valves with Protective Caps.



Description	Product Code	Pack Size	Weight (kg)	Weight (lbs)	Diameter Ø (mm)
UPP Fusion Seal 75mm with Integrated Coupler	303-075-EIF	20	0.24	0.53	75



Description	Product Code	Pack Size	Weight (kg)	Weight (lbs)
Weld Pin Protection Cap	ESI-CAP-012	100	0.004	0.01

Ancillary Items



Description	Product Code	Pack Size	Weight (kg)	Weight (lbs)
Leak Detection Tube Kit - not for use with STB-200 product offering	LDT 60-1	1	0.05	0.11



Description	Product Code	Pack Size	Weight (kg)	Weight (lbs)
Leak Detection Tube Kit - for use with STB-200 product offering	BPT-200	1	0.05	0.11

Note: 63mm Primary Pipe System.
For Termination and Transition Fittings please refer to pages 22 to 25.



UPP 90mm 3" Primary Pipe System

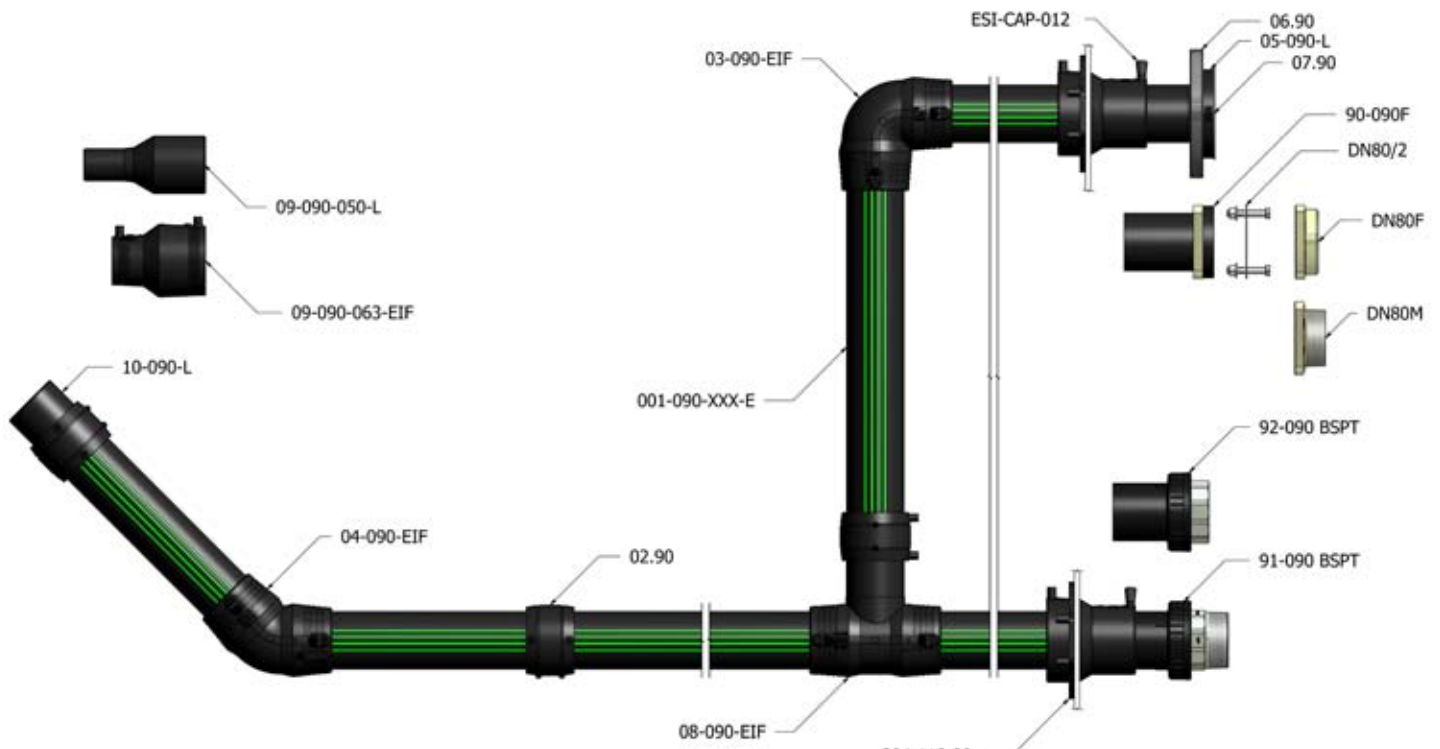

Description	Product Code	Pack Size	Weight (kg/m)	Weight (lbs/ft)	Diameter Ø (mm)
UPP Extra Pipe 90mm L=5.8M	001-090-006-E	204	1.81	1.22	90
UPP Extra Pipe 90mm Coil 50M	001-090-050-E	50	1.81	1.22	90



Description	Product Code	Pack Size	Weight (kg)	Weight (lbs)	Diameter Ø (mm)
UPP Fusion Coupler 90mm	02.90	18	0.2	0.44	90



Description	Product Code	Pack Size	Weight (kg)	Weight (lbs)	Diameter Ø (mm)
UPP Plain Elbow 90° 90mm	03-090-L	8	0.69	1.52	90



Description	Product Code	Pack Size	Weight (kg)	Weight (lbs)	Diameter Ø (mm)
UPP Electrofusion Elbow 90° 90mm	03-090-EIF	15	0.69	1.52	90



Description	Product Code	Pack Size	Weight (kg)	Weight (lbs)	Diameter Ø (mm)
UPP Plain Elbow 45° 90mm	04-090-L	6	0.57	1.26	90



Description	Product Code	Pack Size	Weight (kg)	Weight (lbs)	Diameter Ø (mm)
UPP Electrofusion Elbow 45° 90mm	04-090-EIF	20	0.56	1.23	90



Description	Product Code	Pack Size	Weight (kg)	Weight (lbs)	Diameter Ø (mm)
UPP Stub 90mm	05-090-L	12	0.48	1.06	90
UPP Flange Circular DN80 90mm	06.90	9	1.4	3.09	90
UPP Gasket 90mm for Stub	07.90	10	0.04	0.09	90



NOTE: ANSI version is available.



Description	Product Code	Pack Size	Weight (kg)	Weight (lbs)	Diameter Ø (mm)
UPP Plain Tee Equal 90mm	08-90-L	7	1.02	2.25	90



Description	Product Code	Pack Size	Weight (kg)	Weight (lbs)	Diameter Ø (mm)
UPP Electrofusion Tee 90mm	08-090-EIF	10	0.87	1.92	90



Description	Product Code	Pack Size	Weight (kg)	Weight (lbs)	Diameter Ø (mm)
UPP Reducing Tee 90x63mm	08-090-063-L	15	0.83	1.83	90/63



Description	Product Code	Pack Size	Weight (kg)	Weight (lbs)	Diameter Ø (mm)
UPP Plain Reducer 90x50mm	09-090-050-L	15	0.29	0.64	90/50
UPP Plain Reducer 90x63mm	09-090-063-L	20	0.32	0.71	90/63
UPP Plain Reducer 110x90mm	09-110-090-L	9	0.55	1.25	110/90



Description	Product Code	Pack Size	Weight (kg)	Weight (lbs)	Diameter Ø (mm)
UPP Electrofusion Reducer 90x63mm	09-090-063-EIF	30	0.35	0.77	90/63
UPP Electrofusion Reducer 110x90mm	09-110-090-EIF	16	0.68	1.50	110/90



Description	Product Code	Pack Size	Weight (kg)	Weight (lbs)	Diameter Ø (mm)
UPP End Cap 90mm	10-090-L	18	0.24	0.53	90



Description	Product Code	Pack Size	Weight (kg)	Weight (lbs)
Weld Pin Protection Cap	ESI-CAP-012	100	0.004	0.01



Description	Product Code	Pack Size	Weight (kg)	Weight (lbs)	Diameter Ø (mm)
UPP Flanged Termination 90mm	90-090F	4	1.0	2.20	90
UPP Coupling Flange 3" BSPT Male	DN80M	10	1.312	2.89	3"
UPP Coupling Flange 3" BSP Female	DN80F	20	0.96	2.12	3"
UPP Gasket & Bolt Set for Coupling Flange DN 80	DN80/2	1	0.224	0.49	--



Description	Product Code	Pack Size	Weight (kg)	Weight (lbs)	Diameter Ø (mm)
UPP Termination 90mm x 3" BSPT Male	91-090 BSPT	2	1.61	3.54	90
UPP Termination 90mm x 3" NPT Male	91-090 NPT	2	1.61	3.54	90



Description	Product Code	Pack Size	Weight (kg)	Weight (lbs)	Diameter Ø (mm)
UPP Termination 90mm x 3" BSPT Female	92-090 BSPT	2	1.06	2.34	90
UPP Termination 90mm x 3" NPT Female	92-090 NPT	2	1.06	2.34	90



Description	Product Code	Unit	Weight (kg)	Weight (lbs)	Diameter Ø (mm)
Chain Wrench 125mm Pipe Max All Male and Female 90mm sizes	CW-125-PIPE	1	1.2	2.6	90

UPP 110x90mm Secondary Contained Pipe System - Gemini

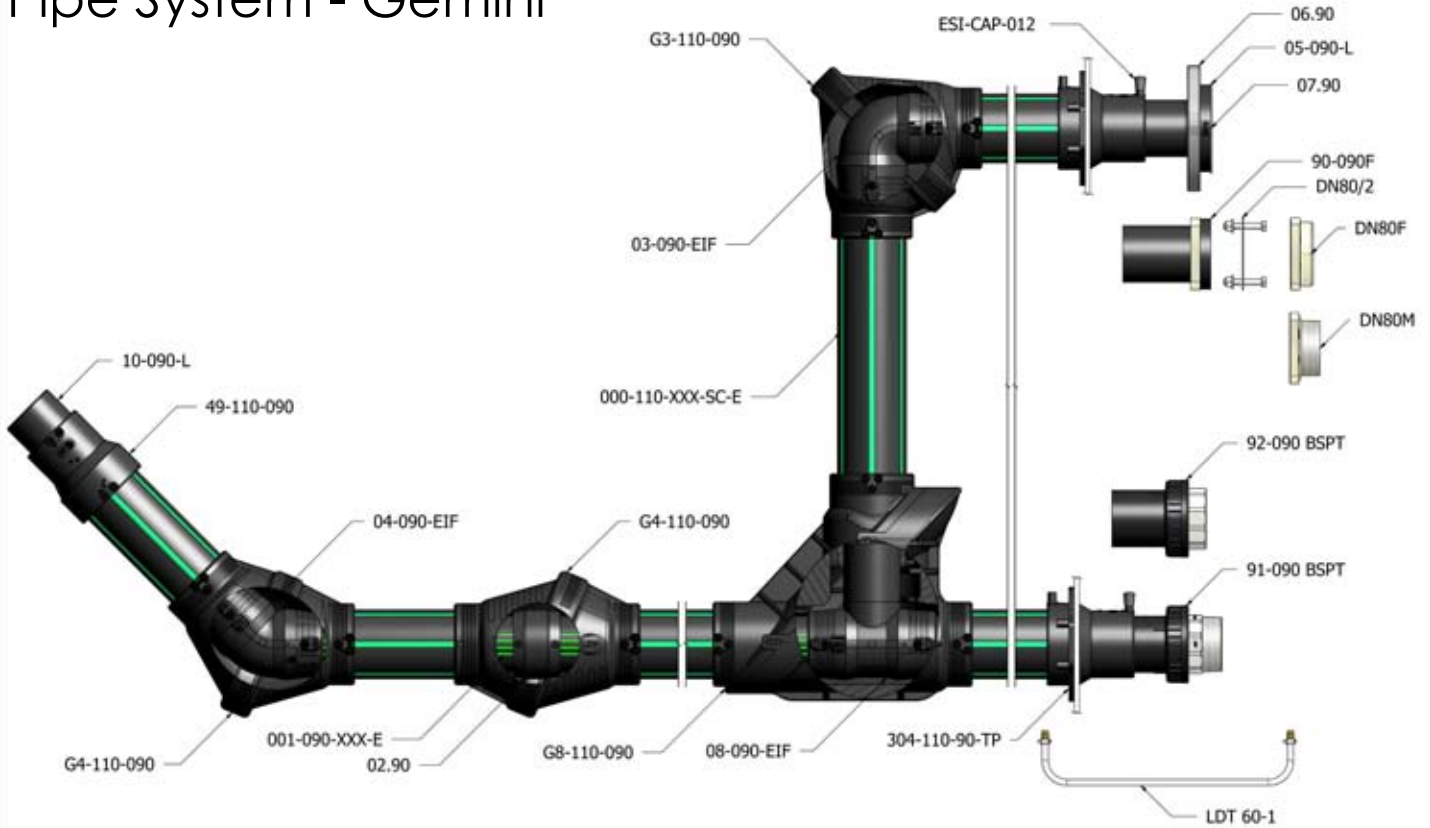

UPP 160x90mm Secondary Contained Pipe System - Legacy

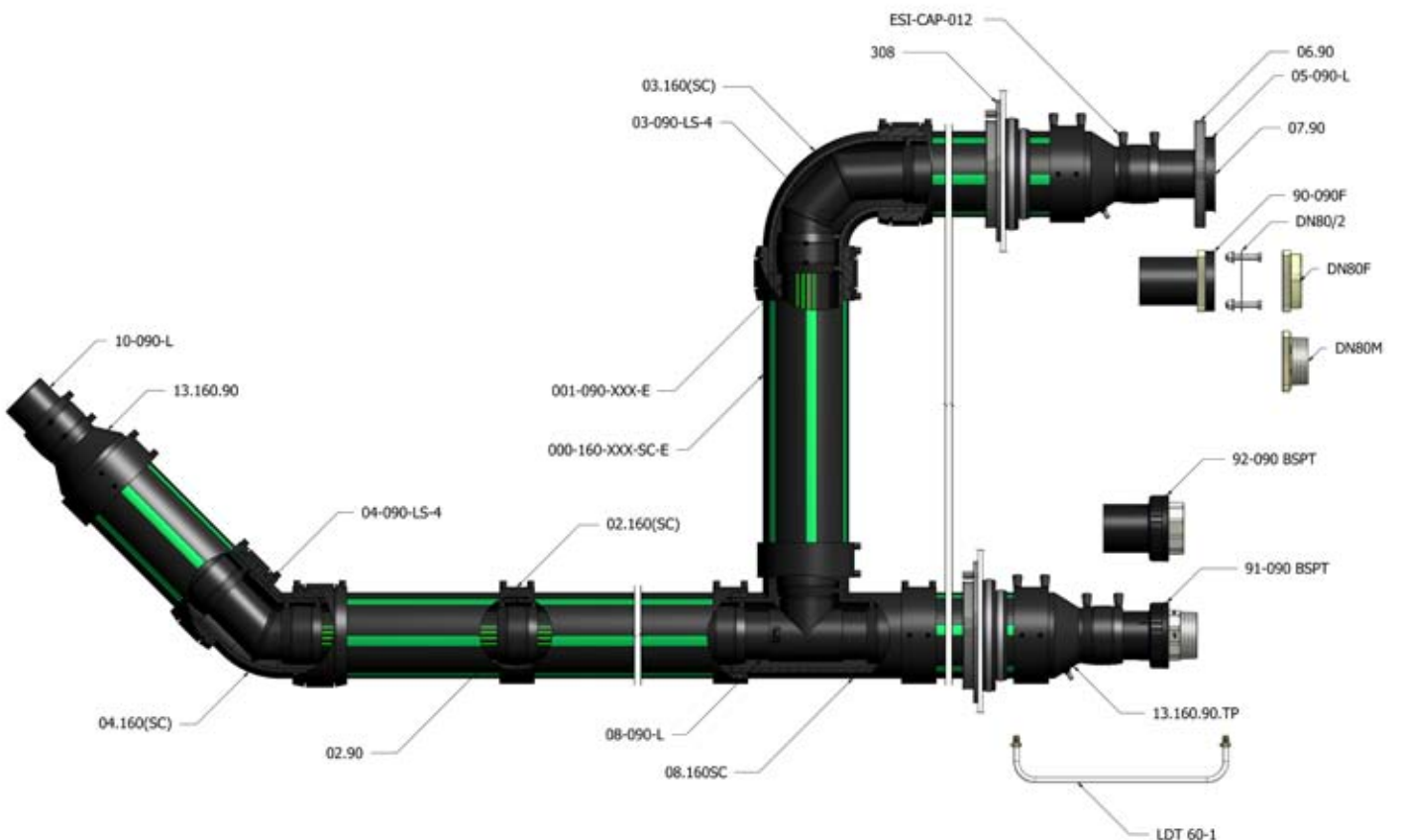



UPP 110x90 Secondary Contained Pipe System - Gemini



Description	Product Code	Pack Size	Weight (kg/m)	Weight (lbs/ft)	Diameter Ø (mm)
SC 110mm Outer Sleeve: 5.8m bar	000-110-006-SC	138	1.46	0.98	110



Description	Product Code	Pack Size	Weight (kg)	Weight (lbs)	Diameter Ø (mm)
SC 110x90 UPP Gemini 90° Elbow	G3-110-090	3	1.95	4.29	110



Description	Product Code	Pack Size	Weight (kg)	Weight (lbs)	Diameter Ø (mm)
SC 110x90 UPP Gemini 45° Elbow OR SC 110x90 UPP Gemini Inline Joint	G4-110-090	4	1.57	3.46	110



Description	Product Code	Pack Size	Weight (kg)	Weight (lbs)	Diameter Ø (mm)
SC 110x90 UPP Gemini Tee	G8-110-090	1	4.41	9.71	110



Description	Product Code	Pack Size	Weight (kg)	Weight (lbs)	Inside Diameter Ø (mm)
SC Welding Reducer 110/90mm with Test Port (pictured)	49-110-090-TP	10	0.5	1.10	110/90
SC Welding Reducer 110/90mm	49-110-090	10	0.5	1.10	110/90



Description	Product Code	Pack Size	Weight (kg)	Weight (lbs)	Diameter Ø (mm)
Fusion E/Seal with 110mm & 90mm Couplers with Test Port (pictured)	304-110-090-TP	10	0.56	1.23	90
Fusion Entry Seal with 110 & 90mm Couplers	304-110-090	5	0.56	1.23	90



Description	Product Code	Pack Size	Weight (kg)	Weight (lbs)
Weld Pin Protection Cap Primary & SC	ESI-CAP-012	100	0.004	0.01

Ancillary Items



Description	Product Code	Pack Size	Weight (kg)	Weight (lbs)
Leak Detection Tube Kit - not for use in STB product offering	LDT 60-1	1	0.05	0.11



Description	Product Code	Pack Size	Weight (kg)	Weight (lbs)
Leak Detection Tube Kit - for use in STB product offering	BPT-200	1	0.05	0.11

Note: 90mm Primary Pipe System.
For Termination and Transition Fittings please refer to pages 29 to 31

UPP 160x90mm 3" Secondary Contained Pipe System



Description	Product Code	Pack Size	Weight (kg/m)	Weight (lbs/ft)	Diameter Ø (mm)
UPP Secondary Pipe 160mm L=6M	000-160-006-SC-E	54	3.02	2.10	160



Description	Product Code	Pack Size	Weight (kg)	Weight (lbs)	Diameter Ø (mm)
UPP Fusion Coupler 160mm Secondary	02.160(SC)	20	0.33	0.73	160
UPP Fusion Coupler 160mm Primary	02.160	4	0.53	1.17	160



Description	Product Code	Pack Size	Weight (kg)	Weight (lbs)	Diameter Ø (mm)
UPP Extra 90° Formed Bend 90mm	03-090-LS-4	10	0.71	1.57	90
UPP Elbow 90° 160mm Secondary	03.160(SC)	5	0.95	2.09	160



Description	Product Code	Pack Size	Weight (kg)	Weight (lbs)	Diameter Ø (mm)
UPP Extra 45° Formed Bend 90mm	04-090-LS-4	10	0.47	1.04	90
UPP Elbow 45° 160mm Secondary	04.160(SC)	5	0.7	1.54	160



Description	Product Code	Pack Size	Weight (kg)	Weight (lbs)	Diameter Ø (mm)
UPP Tee Equal Long 90mm MODIFIED	08.90.L-1	7	0.86	1.90	90
UPP Tee Equal 160mm Secondary	08.160(SC)	5	1.16	2.56	160



Description	Product Code	Pack Size	Weight (kg)	Weight (lbs)	Diameter Ø (mm)
UPP Reducer 160x110mm Secondary (pictured)	09.160.110(SC)	5	0.2	0.44	160/110
UPP Reducer 160x125mm Secondary	09.160.125(SC)	5	0.21	0.46	160/125



Description	Product Code	Pack Size	Weight (kg)	Weight (lbs)	Diameter Ø (mm)
UPP Terminating Reducer 160x90mm Secondary	13.160.90	10	0.62	1.37	160/90
UPP Terminating Reducer 160x90mm Secondary with Test Port (pictured)	13.160.90.TP	10	0.65	1.43	160/90



Description	Product Code	Pack Size	Weight (kg)	Weight (lbs)	Diameter Ø (mm)
UPP Terminating Reducer 110x90mm Secondary	49-110-090	10	0.5	1.10	110/90
UPP Terminating Reducer 110x90mm Secondary with Test Port (pictured)	49-110-090-TP	10	0.51	1.12	110/90



Description	Product Code	Pack Size	Weight (kg)	Weight (lbs)
Weld Pin Protection Cap	ESI-CAP-012	100	0.004	0.01

Ancillary Items



Description	Product Code	Pack Size	Weight (kg)	Weight (lbs)
Leak Detection Tube Kit - not for use in STB product offering	LDT 60-1	1	0.05	0.11



Description	Product Code	Pack Size	Weight (kg)	Weight (lbs)
Leak Detection Tube Kit - for use in STB product offering	BPT-200	1	0.05	0.11

Note: 90mm Primary Pipe System.
For Termination and Transition Fittings please refer to pages 29 to 31

UPP 110mm 4" Primary Pipe System

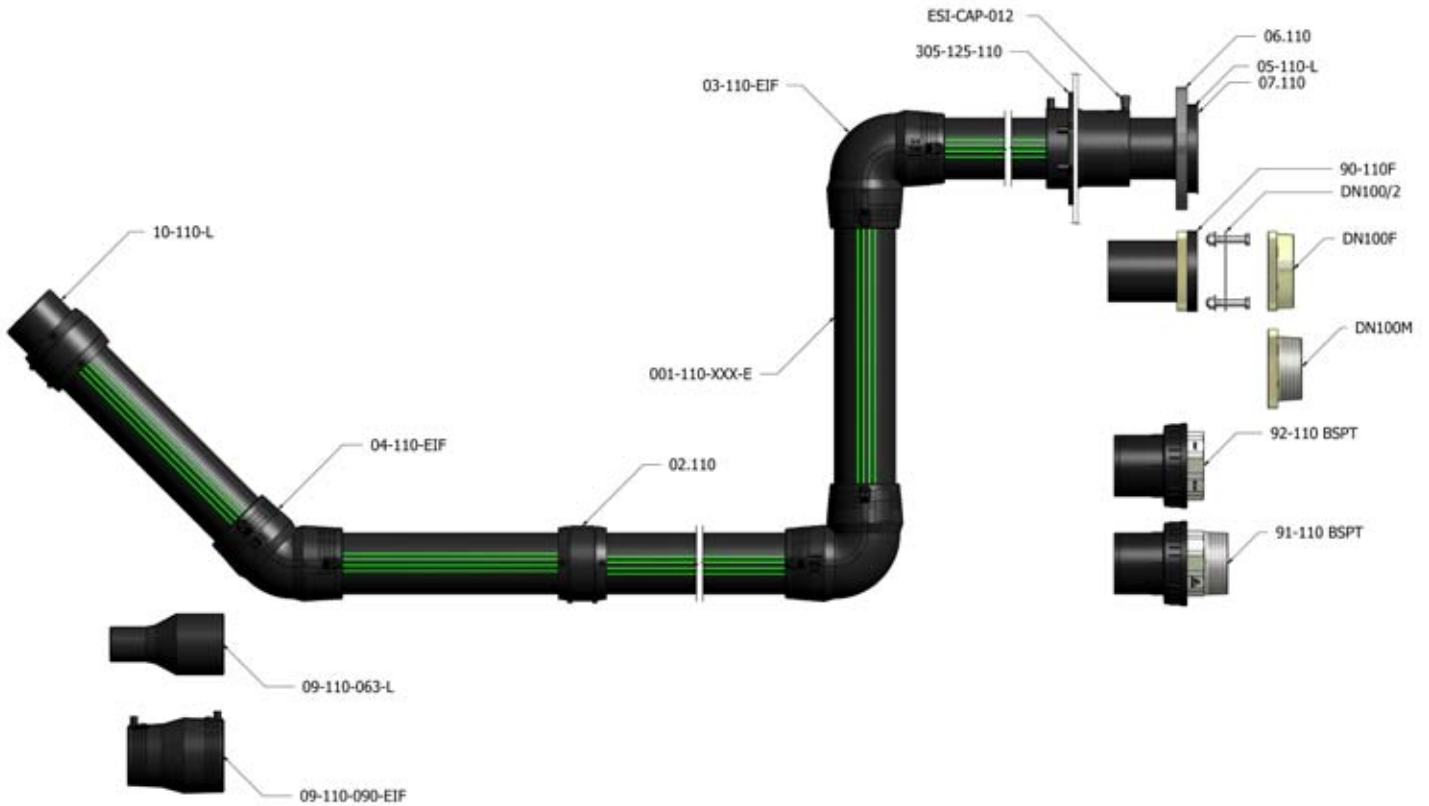

Description	Product Code	Pack Size	Weight (kg/m)	Weight (lbs/ft)	Diameter Ø (mm)
UPP Extra Pipe 110mm L=6M	001-110-006-E	138	3.15	2.12	110



Description	Product Code	Pack Size	Weight (kg/m)	Weight (lbs/ft)	Diameter Ø (mm)
UPP Extra FILL/VENT Pipe 110mm L=6M	001-110-006-FILL-E	138	2.3	1.55	110
UPP Extra FILL/VENT Pipe Coil 50M	001-110-050-FILL-E	50	2.3	1.55	110



Description	Product Code	Pack Size	Weight (kg)	Weight (lbs)	Diameter Ø (mm)
UPP Fusion Coupler 110mm	02.110	15	0.36	0.79	110



Description	Product Code	Pack Size	Weight (kg)	Weight (lbs)	Diameter Ø (mm)
UPP Plain Elbow 90° 110mm	03-110-L	8	1.14	2.51	110



Description	Product Code	Pack Size	Weight (kg)	Weight (lbs)	Diameter Ø (mm)
UPP Electrofusion Elbow 90° 110mm	03-110-EIF	8	1.18	2.60	110



Description	Product Code	Pack Size	Weight (kg)	Weight (lbs)	Diameter Ø (mm)
UPP Plain Elbow 45° 110mm	04-110-L	12	0.92	2.03	110



Description	Product Code	Pack Size	Weight (kg)	Weight (lbs)	Diameter Ø (mm)
UPP Electrofusion Elbow 45° 110mm	04-110-EIF	12	0.97	2.14	110



Description	Product Code	Pack Size	Weight (kg)	Weight (lbs)	Diameter Ø (mm)
UPP Stub 110mm	05-110-L	8	0.7	1.54	110
UPP Flange Circular DN100 110mm	06.110	13	1.44	3.17	110
UPP Gasket 110mm for Stub	07.110	10	0.042	0.09	110



NOTE: ANSI version is available.



Description	Product Code	Pack Size	Weight (kg)	Weight (lbs)	Diameter Ø (mm)
UPP Plain Tee Equal 110mm	08-110-L	5	1.63	3.59	110



Description	Product Code	Pack Size	Weight (kg)	Weight (lbs)	Diameter Ø (mm)
UPP Electrofusion Tee 110mm	08-110-EIF	6	1.53	3.37	110



Description	Product Code	Pack Size	Weight (kg)	Weight (lbs)	Diameter Ø (mm)
UPP Reducing Tee 110x63mm	08.110.063(L)	10	1.27	2.80	110



Description	Product Code	Pack Size	Weight (kg)	Weight (lbs)	Diameter Ø (mm)
UPP Plain Reducer 110x63mm	09-110-063-L	10	0.47	1.04	110/63
UPP Plain Reducer 110x90mm	09-110-090-L	9	0.55	1.21	110/90
UPP Plain Reducer 160x110mm	09-160-110-L	4	1.24	2.73	160/110



Description	Product Code	Pack Size	Weight (kg/m)	Weight (lbs/ft)	Diameter Ø (mm)
UPP Electrofusion Reducer 110x90mm	09-110-090-EIF	16	0.68	1.50	110/90



Description	Product Code	Pack Size	Weight (kg)	Weight (lbs)	Diameter Ø (mm)
UPP End Cap 110mm	10-110-L	12	0.38	0.84	110



Description	Product Code	Pack Size	Weight (kg)	Weight (lbs)
Weld Pin Protection Cap Primary & SC	ESI-CAP-012	100	0.004	0.01



Description	Product Code	Pack Size	Weight (kg)	Weight (lbs)	Diameter
O Ring for 12.110	12.110.OR	1	0.002	0.004	110



Description	Product Code	Pack Size	Weight (kg)	Weight (lbs)	Diameter Ø (mm)
UPP Flanged Termination 110mm	90-110F	2	1.9	4.9	110
UPP Coupling Flange 4" BSPT Male	DN100M	1	2.44	5.38	4"
UPP Coupling Flange 4" NPT Male	DN100M NPT	1	2.44	5.38	4"
UPP Coupling Flange 4" BSP Female	DN100F	1	2.042	4.50	4"
UPP Gasket & Bolt Set for Coupling Flange DN 100	DN100/2	1	0.33	0.73	--



Description	Product Code	Pack Size	Weight (kg)	Weight (lbs)	Diameter Ø (mm)
UPP Termination 110mm x 4" BSPT Male	91-110 BSPT	2	2.93	6.46	110
UPP Termination 110mm x 4" NPT Male	91-110 NPT	2	2.93	6.46	110



Description	Product Code	Pack Size	Weight (kg)	Weight (lbs)	Diameter Ø (mm)
UPP Termination 110mm x 4" BSPT Female	92-110 BSPT	2	1.94	4.28	110
UPP Termination 110mm x 4" NPT Female	92-110 NPT	2	1.94	4.28	110



Description	Product Code	Unit	Weight (kg)	Weight (lbs)	Diameter Ø (mm)
Chain Wrench 125mm Pipe Max All Male and Female 90mm sizes	CW-125-PIPE	1	1.2	2.6	90

UPP 125x110mm Secondary Contained Pipe System - Gemini



Description	Product Code	Pack Size	Weight (kg/m)	Weight (lbs/ft)	Diameter (mm)
SC 125mm Outer Sleeve: 5.8m stick length	000-125-006-SC-E	108m	1.89	1.27	125



Description	Product Code	Pack Size	Weight (kg)	Weight (lbs)	Diameter (mm)
SC 125x110 UPP Gemini 90° Elbow	G3-125-110	2	3.15	6.94	125



Description	Product Code	Pack Size	Weight (kg)	Weight (lbs)	Diameter Ø (mm)
SC 125x90 UPP Gemini 45° Elbow OR SC 125x90 UPP Gemini Inline Joint	G4-125-110	2	2.14	4.71	125



Description	Product Code	Pack Size	Weight (kg)	Weight (lbs)	Diameter Ø (mm)
SC Welding Reducer 125/110mm with Test Port (pictured)	49-125-110-TP	10	0.75	1.65	125/110
SC Welding Reducer 125/110mm	49-125-110	10	0.617	1.36	125/110



Description	Product Code	Pack Size	Weight (kg)	Weight (lbs)	Diameter Ø (mm)
Electrofusion Seal 125 & 110 Couplers with Test Port (pictured)	305-125-110-TP	10	0.92	2.03	110
Electrofusion Seal with 125 & 110 Couplers	305-125-110	5	0.91	2.01	110



Description	Product Code	Pack Size	Weight (kg)	Weight (lbs)
Weld Pin Protection Cap Primary & SC	ESI-CAP-012	100	0.004	0.01

Ancillary Items



Description	Product Code	Pack Size	Weight (kg)	Weight (lbs)
Leak Detection Tube Kit - not for use in STB product offering	LDT 60-1	1	0.05	0.11



Description	Product Code	Pack Size	Weight (kg)	Weight (lbs)
Leak Detection Tube Kit - for use in STB product offering	BPT-200	1	0.05	0.11

Note: 110mm Primary Pipe System.
For Termination and Transition Fittings please refer to pages 36 to 38



UPP 160x110mm 4" Secondary Contained Pipe System



Description	Product Code	Pack Size	Weight (kg/m)	Weight (lbs/ft)	Diameter Ø (mm)
UPP Secondary Pipe 160mm L=6M	000-160-006-SC-E	54m	3.02	2.10	160



Description	Product Code	Pack Size	Weight (kg)	Weight (lbs)	Diameter Ø (mm)
UPP Fusion Coupler 160mm Secondary	02.160(SC)	20	0.33	0.73	160
UPP Fusion Coupler 160mm Primary	02.160	4	0.53	1.17	160



Description	Product Code	Pack Size	Weight (kg)	Weight (lbs)	Diameter Ø (mm)
UPP 90° Formed Bend 110mm	03-110-LS-4	10	1.08	2.38	110
UPP Elbow 90° 160mm Secondary	03.160(SC)	5	0.95	2.09	160



Description	Product Code	Pack Size	Weight (kg)	Weight (lbs)	Diameter Ø (mm)
UPP 45° Formed Bend 110mm	04-110-LS-4	10	0.72	1.59	110
UPP Elbow 45° 160mm Secondary	04.160(SC)	5	0.7	1.54	160



Description	Product Code	Pack Size	Weight (kg)	Weight (lbs)	Diameter Ø (mm)
UPP Reducer 160x110mm Secondary	09.160.110(SC)	5	0.2	0.44	160/110
UPP Reducer 160x125mm Secondary	09.160.125(SC)	5	0.21	0.46	160/125



Description	Product Code	Pack Size	Weight (kg)	Weight (lbs)	Diameter Ø (mm)
UPP Terminating Reducer 160x110mm Secondary	13.160.110	10	0.55	1.21	160/110
UPP Terminating Reducer 160x110mm Secondary with Test Port	13.160.110.TP	10	0.583	1.29	160/110



Description	Product Code	Pack Size	Weight (kg)	Weight (lbs)
Weld Pin Protection Cap	ESI-CAP-012	100	0.004	0.01

Ancillary Items



Description	Product Code	Pack Size	Weight (kg)	Weight (lbs)
Leak Detection Tube Kit - not for use in STB product offering	LDT 60-1	1	0.05	0.11



Description	Product Code	Pack Size	Weight (kg)	Weight (lbs)
Leak Detection Tube Kit - for use in STB product offering	BPT-200	1	0.05	0.11

Note: 110mm Primary Pipe System.
For Termination and Transition Fittings please refer to pages 36 to 38

UPP 160mm 6" Primary Pipe System

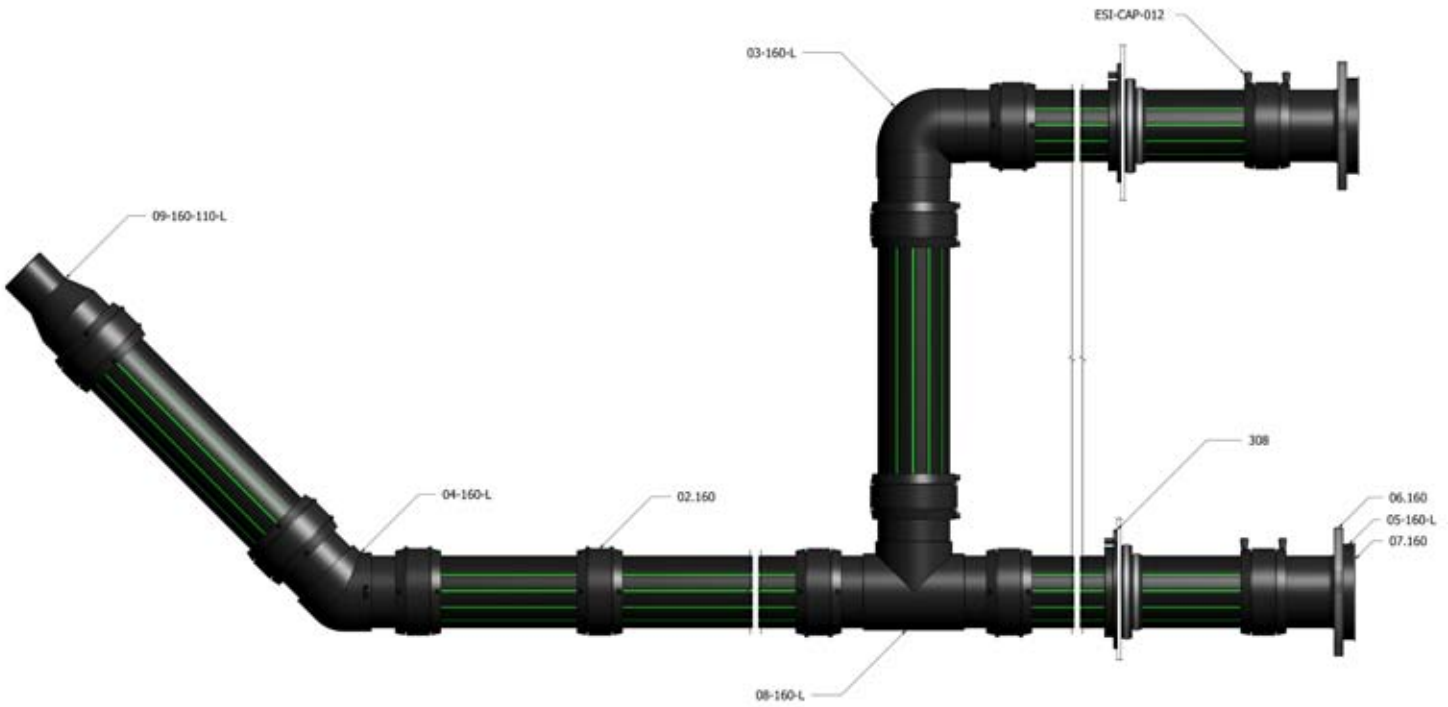

Description	Product Code	Pack Size	Weight (kg/m)	Weight (lbs/ft)	Diameter Ø (mm)
UPP Extra Pipe 160mm L=11.5M NOTE: Black with nylon barrier. EN 14125 T2.	001-160-011	11.5	5.49	3.69	160



Description	Product Code	Pack Size	Weight (kg)	Weight (lbs)	Diameter Ø (mm)
UPP Fusion Coupler 160mm	02.160	4	0.53	1.17	160



Description	Product Code	Pack Size	Weight (kg)	Weight (lbs)	Diameter Ø (mm)
UPP Plain Elbow 90° 160mm	03-160-L	5	3.13	6.90	160



Description	Product Code	Pack Size	Weight (kg)	Weight (lbs)	Diameter Ø (mm)
UPP Plain Elbow 45° 160mm	04-160-L	6	1.4	3.09	160



Description	Product Code	Pack Size	Weight (kg)	Weight (lbs)	Diameter Ø (mm)
UPP Stub 160mm	05-160-L	6	1.66	3.66	160
UPP Flange Circular DN100 160mm	06.160	1	5.52	12.17	150/160
UPP Gasket 160mm for Stub	07.160	10	0.1	0.22	160



NOTE: ANSI version is available.



Description	Product Code	Pack Size	Weight (kg)	Weight (lbs)	Diameter Ø (mm)
UPP Plain Tee Equal 160mm	08-160-L	3	0.84	1.85	160



Description	Product Code	Pack Size	Weight (kg)	Weight (lbs)	Diameter Ø (mm)
UPP Plain Reducer 160x110mm	09-160-110-L	4	1.24	2.73	160/110



Description	Product Code	Pack Size	Weight (kg)	Weight (lbs)
Weld Pin Protection Cap Primary & SC	ESI-CAP-012	100	0.004	0.01

UPP 110mm 4" Duct System

With a thick and robust wall, the new duct is equally flexible and can be welded to electrofusion entry seals and other 110mm electrofusion fittings. The duct will provide a water tight chase for pipes or electrical cables when fully welded.

This product is for use as an electrical duct or gravel guard for fuel pipework.

The following in-house testing has been satisfactorily carried out on the duct:

- Electrofusion trials.
- Cold temperature bending tests at -29°C.
- Ball impact test at -29°C.
- Pressure testing at 2 bar for 1 week.
- Drop test of coil from 2 metres (6 feet).



00-110-050-DUCT

Description	Product Code	Pack Size	Weight (kg/m)	Weight (lbs/ft)	Diameter Ø (mm)
110mm Flexible PE Duct Coil 50m	00-110-050-DUCT	50	2.3	1.55	110
Description	Product Code	Pack Size	Weight (kg)	Weight (lbs)	Diameter Ø (mm)
UPP Fusion Coupler 110mm	02.110	15	0.36	0.79	110
UPP Fusion Coupler 125mm Secondary	02.125(SC)	25	0.192	0.42	125
UPP Reducer 125x110mm Secondary	09.125.110(SC)	40	0.146	0.32	125/110
UPP End Cap 125mm Secondary	10.125(SC)	10	0.14	0.31	125
UPP Terminating Reducer 125x110mm Secondary	49-125-110	10	0.62	1.36	125/110
UPP Terminating Reducer 125x110mm Sec with Test Port	49-125-110-TP	10	0.75	1.65	125/110
UPP Fusion Entry Seal with Coupler 110mm with Test Port (No Boot)	304-110-TP	10	0.44	0.97	110
UPP 305 - 5" Fusion Ring Extended Spigot	305-R-1	10	0.3	0.66	125
Weld Pin Protection Cap	ESI-CAP-012	100	0.004	0.01	--





Advantages

302-040

Electrofusion seal for 40/32mm pipe.

- 302-040 seal complements 32mm pipe range.
- 40mm secondary (double wall) pipe welds directly to seal spigot using 02.40(SC) fusion coupler.
- 32mm primary (single wall) continues through penetration and into PE sump/chamber and is fusion sealed with 49.040.032 (ordered separately).

303 Series

Electrofusion seal with integrated coupler.

- Integrated coupler welds directly to UPP primary or secondary pipe and eliminates the need for a rubber boot or band clamp.
- Once welded to the chamber wall the seal is liquid tight for the life of the installation.
- Available for 50mm (1½") and 63mm (2") double wall and 63mm (2") single wall UPP pipe.

304 & 305 Series

Electrofusion seal.

- Space saving, welded entry seal.
- For use with 50mm (1½"), 63mm (2"), 75mm (SC), 90mm (3"), 110mm (4") SW or DW pipe.
- With or without test port.

308 Series

Electrofusion seal.

- Large diameter access.
- For use with 50mm (1½"), 63mm (2"), 75mm (SC), 90mm (3"), 110mm (4") and 160mm (6") pipe.
- With or without test port on boot.

APT Flexible Entry Boots

APT flexible entry boots are two-piece boots that double the sealing power of your entry boots. Stainless steel studs and corrosion resistant nuts and backing rings make for the highest quality entry boot. Franklin Fueling Systems offers a complete line of sizes for single and secondary containment pipe. Also available in a ducted boot version to accommodate the use of APT DCT-400 corrugated ducting for easy retractability.



Description	Product Code	Pack Size	UPP Pipe Diameter Ø (mm)	Hole Diameter (mm)	Hole Saw
Flexible Entry Boot for 1" Electrical Conduit	FEB-075-SC	1	32	50	HSCS2
Flexible Entry Boot for 3/4" and 1" Electrical Conduit	FEB-100-D	1	32	50	HSCS2
Flexible Entry Boot for 40mm UPP	FEB-100-SC	1	40	50	HSCS2
Flexible Entry Boot for 50mm UPP	FEB-150-D	1	50	88	HSP3
Flexible Entry Boot for 63mm UPP	FEB-175-SC	1	63	88	HSP3
Flexible Entry Boot for 63mm UPP	FEB-200-D	1	63	88	HSP3
Flexible Entry Boot for 75mm UPP	FEB-200-SC	1	75	88	HSP3
Flexible Entry Boot for 90mm UPP	FEB-300-R	1	90	88	HSP3
Flexible Entry Boot for 110mm UPP	FEB-400-R	1	110	139	HS5
Flexible Entry Boot for 125mm UPP	FEB-400-F	1	125	139	HS5
PetroSeal for 50 / 63 / 75mm UPP	PS3	1	50, 63, 75	83	HSP3
PetroSeal for 90 / 110 / 160mm UPP	PS6	1	90, 110, 160	168	HSP6

UPP Fusion Entry Seals

These electrofusion entry seals weld directly to the walls of polyethylene chambers or sumps. They have been specifically designed to reduce the number of fittings necessary to provide water tight seals between the underground tank sump/chamber and the UPP primary or secondary contained pipe and electrical conduit or duct.

The nature of the seal means that after installation it becomes one with the sump, with zero leak paths, creating a 100% leak tight system. The seals are polyethylene based allowing electrofusion of UPP pipework systems directly to the penetration, negating the need for mechanical boots and creating a homogeneous structure of the sump, boot and pipe. The spigot on both sides of the 305 and 308 allow a second boot to be fitted to the outside as a gravel guard.

The seal is fully vacuum and pressure testable ensuring 100% leak free seals and sumps.

Note: See page 79 for Hole Saws



Description	Product Code	Pack Size	Weight (kg)	Weight (lbs)	Diameter Ø (mm)
UPP Fusion Seal 40mm	302-040	45	0.1	0.22	40



Description	Product Code	Pack Size	Weight (kg)	Weight (lbs)	Diameter Ø (mm)
UPP Fusion Seal 63mm with Integrated Coupler	303-063-EIF	20	0.24	0.53	63
UPP Fusion Seal 75mm with Integrated Coupler	303-075-EIF	20	0.24	0.53	75



Description	Product Code	Pack Size	Weight (kg)	Weight (lbs)	Diameter Ø (mm)
UPP Retrofit Fusion Plate for 303 Fusion Seals	306-EIF	10	0.4	0.88	63 / 75



Description	Product Code	Pack Size	Weight (kg)	Weight (lbs)	Diameter Ø (mm)
Fusion Entry Seal with Secondary Coupler 110x50mm with Test Port	304-110-050-TP	10	0.49	1.08	140
Fusion Entry Seal with Secondary Coupler 110x63mm with Test Port	304-110-063-TP	10	0.49	1.08	140
Fusion Entry Seal with Secondary Coupler 110x75mm with Test Port (pictured)	304-110-075-TP	10	0.44	0.97	140



Description	Product Code	Pack Size	Weight (kg)	Weight (lbs)	Diameter Ø (mm)
UPP Fusion Entry Seal 110x90mm	304-110-090	5	0.56	1.23	90/110
UPP Fusion Entry Seal 110x90mm with Test Port (pictured)	304-110-090-TP	10	0.56	1.23	90/110



Description	Product Code	Pack Size	Weight (kg)	Weight (lbs)	Diameter Ø (mm)
UPP Fusion Entry Seal with Coupler 110 with Test Port (No Boot)	304-110-TP	10	0.44	0.97	110



Description	Product Code	Pack Size	Weight (kg)	Weight (lbs)	Diameter Ø (mm)
UPP 5" Fusion Seal for 50/63/75mm	305	10	0.44	0.97	50/63/75



Description	Product Code	Pack Size	Weight (kg)	Weight (lbs)	Diameter Ø (mm)
UPP 5" Fusion Ring Extended	305-R-1	10	0.3	0.66	125



Description	Product Code	Unit	Weight (kg)	Weight (lbs)	Diameter Ø (mm)
UPP Seal Boot Kit for 50/63/75mm	305-SB	20	0.2	0.44	50/63/75



Description	Product Code	Pack Size	Weight (kg)	Weight (lbs)	Diameter Ø (mm)
UPP Seal Boot Kit for UPP 90mm	305-090-SB	10	0.16	0.35	90



Description	Product Code	Pack Size	Weight (kg)	Weight (lbs)	Diameter Ø (mm)
Seal Boot Kit for UPP 110mm	DCT-400-F	25	0.18	0.40	110



Description	Product Code	Pack Size	Weight (kg)	Weight (lbs)	Diameter Ø (mm)
UPP 5" Fusion Seal - Electrical Entry	305 ELECTRICAL	10	0.5	1.10	12/18/32/41
Spare Boot 305 Electrical	305 ELECTRIC SB	20	0.3	0.66	12/18/32/40



Description	Product Code	Pack Size	Weight (kg)	Weight (lbs)	Diameter Ø (mm)
UPP Fusion Entry Seal 125x110mm	305-125-110	5	0.91	2.01	110
UPP Fusion Entry Seal 125x110mm with Test Port	305-125-110-TP	10	0.92	2.03	110



Description	Product Code	Pack Size	Weight (kg)	Weight (lbs)	Diameter Ø (mm)
UPP 8" Fusion Seal for 90/110/160mm	308	5	0.66	1.46	90/110/160



Description	Product Code	Pack Size	Weight (kg)	Weight (lbs)	Diameter Ø (mm)
UPP 8" Fusion Ring	308-R	5	0.3	0.66	200



Description	Product Code	Unit	Weight (kg)	Weight (lbs)	Diameter Ø (mm)
UPP Seal Boot Kit for 90/110/160mm	308-SB	20	0.34	0.75	90/110/160



Description	Product Code	Pack Size	Weight (kg)	Weight (lbs)	Diameter Ø (mm)
UPP 8" Fusion Seal with Rubber Boot 75/63/50mm	308-075	5	0.66	1.46	50/63/75



Description	Product Code	Pack Size	Weight (kg)	Weight (lbs)	Diameter Ø (mm)
UPP 8" Seal Boot Kit for 75/63/50mm	308-075-SB	10	0.66	1.46	50/63/75



Description	Product Code	Pack Size	Weight (kg)	Weight (lbs)
Weld Pin Protection Cap	ESI-CAP-012	100	0.004	0.01



Description	Product Code	Pack Size	Weight (kg)	Weight (lbs)	Diameter
UPP Test Port	TP	10	0.02	0.04	7

NOTE: See Page 80 for Hole Punch.



Description	Product Code	Pack Size	Weight (kg)	Weight (lbs)	Diameter Ø (mm)
PetroSeal for 50mm - 75mm UPP	PS3	20	0.62	1.38	50/63/75

NOTE: 63/50 clip is standard. See below for SS4 for 75mm.



Description	Product Code	Pack Size	Weight (kg)	Weight (lbs)	Diameter
Backing Ring for UPP PS3	PS3/R	1	0.25	0.55	n/a

NOTE: Required with PE sumps.



Description	Product Code	Pack Size	Weight (kg)	Weight (lbs)	Diameter Ø (mm)
Band Clip 71mm - 95mm for UPP PS3	SS 4	100	0.04	0.09	70 - 90



Description	Product Code	Unit	Weight (kg)	Weight (lbs)	Diameter Ø (mm)
PetroSeal for 90mm - 160mm UPP	PS6	10	1.12	2.46	90/110/160

NOTE: SS5 clip is standard. See below for SS8 for 160mm.



Description	Product Code	Pack Size	Weight (kg)	Weight (lbs)	Diameter Ø (mm)
Backing Ring for UPP PS6	PS6/R	1	0.42	0.93	--

NOTE: Required with PE sumps.



Description	Product Code	Pack Size	Weight (kg)	Weight (lbs)	Diameter Ø (mm)
Band Clip for UPP PS6 (76-127mm)	SS 5	10	0.05	0.11	90/110/



Description	Product Code	Pack Size	Weight (kg)	Weight (lbs)	Diameter Ø (mm)
Band Clip for PS6/308 (165-216mm) for 160mm	SS 8	50	0.08	0.18	160

Fibre Glass Entry Boot



Description	Product Code	Pack Size	Weight (kg)	Weight (lbs)	Ø (mm)
UPP FGlass Entry Seal Single Sided 125mm	FEB-S-125	2	2.35	5.18	125

Ancillary Items

Description	Product Code	Pack Size	Weight (kg)	Weight (lbs)
Emery Cloth 50 Metre Roll ONLY	EMERY	1	-	-
GRP Entry Fitting Wrench 125mm	FEB-110-TOOL	1	0.32	0.71
E32 ADHESIVE	FEB-E32	1	0.08	0.18
E32 Applicator	FEB-E32-AP	1	0.172	0.38
E32 Nozzle	FEB-E32-NOZ	1	0.004	0.01
Fibreglass Filler UPOL Black 1.1 litre tin	FFU-B	1	2.1	4.63



EMERY



FEB-110-TOOL



FEB-E32



FEB-E32-AP



FFU-B

PetroTite PE Chambers for Underground Tank Access

Dramatically Reduced Leak Paths

With the PetroTite Standard and Optimum fusion chambers the riser section electrofuses to the base, removing the need for multiple bolt holes and foam gaskets in this area, therefore dramatically reducing the number of potential leak paths.

Reduced Installation Time

With its simplified assembly, this electrofusion system also reduces the installation time. Welding of the chamber can be performed using UPP electrofusion equipment in approximately six minutes.

No Leak Points

Once welded and cooled the base and riser of the LA or OCH models become one homogeneous unit, with no mechanical joints and no leak points. The chamber can then be vacuum tested to ensure that it is 100% leak-tight.

Easy Installation

The base of the Optimum chamber is available as either Deep or Shallow bases, and both will allow for a very easy installation of pipework before the riser is fused into place. The LA Chamber is available in Deep or Shallow risers.



Advantages

- With the PetroTite Standard and Optimum fusion chambers the riser electrofuses to the chamber base - no bolts, no leaks. Quick installation with no bolt holes.
- Vacuum testable. Specific testing at critical points ensures a leak-proof installation.
- Tank access remains dry and protected even in high water table areas.
- Compatible with all UPP electrofusion entry seals. Fully welded UPP system, eliminating mechanical joints and leaks.
- The two-piece design enables easy access during installation while the compact design allows for economy in shipping.

Note: Select Pipe Entry Boots or Seals from pages 45 - 49



PetroTite PE Tank Access Chambers

Description	Product Code	Pack Size	Weight (kg)	Weight (lbs)	Neck Opening	Overall Height
PetroTite PE Chamber 1.2 x 1.2 m	DC4830SB	1	78	172.0	720mm x 720mm	max = 1668 min = 1072
PetroTite PE Chamber BASE ONLY 1.2 x 1.2 m	DC4828 (BASE)	1	49	107.8	--	740
Gasket Kit for DC4830SB - Base & Waist	DC4830SBG	1	3.04	6.7	--	--



Full set code: DC4830SB	
40' container loading:	28 sets
Set shipping weight (approx.):	78Kg (171.6 lbs)
Set shipping dimensions:	1370mm x 1370mm x 920mm (54" x 54" x 36")

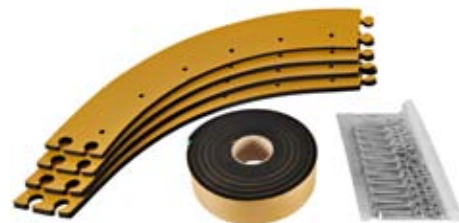

DC4830SBG

PetroTite PE Standard Fusion Chamber

Description	Product Code	Size (mm)	Pack Size	Weight (kg)	Weight (lbs)	Neck Opening	Overall Height (mm)
PE Chamber Deep Burial Set 1.1 x 1.1 m	LA-002-001	1641 x 1176	1	75	165.3	780mm	max = 1641 min = 1310
PE Chamber Shallow Burial Set 1.1 x 1.1 m	LA-002-002	1279 x 1176	1	60	132.3	780mm	max = 1279 min = 831



Full set code: LA-002-001 / LA-002-002	
40' container loading:	10 x 2 x 2 = 40 sets
Welding lead code:	EF1-C7A
Water-tight lid only code:	LA-007-001
Base only code:	LA-004-001
Deep riser only code:	LA-005-001
Set shipping weight (approx.):	75Kg (165.3 lbs)
Set shipping dimensions:	1176mm x 1176mm x 1121mm (46.3" x 46.3" x 44.1")
Shallow riser only code:	LA-006-002
Set shipping weight (approx.):	60Kg (132 lbs)
Set shipping dimensions:	1176mm x 1176mm x 875mm (46.3" x 46.3" x 34.5")

NOTE: Toggles OCH-1400-T included.

Optimum Fusion Chambers

Description	Product Code	Size (mm)	Pack Size	Weight (kg)	Weight (lbs)	Neck Opening	Overall Height (mm)
PE Chamber Deep Burial 1400	OCH-1400-D	1400 x 1616	1	92	203	980mm	max = 1616 min = 1176
PE Chamber Shallow Burial 1400	OCH-1400-S	1400 x 1266	1	80	176	980mm	max = 1266 min = 826



Full set code: OCH-1400-D / OCH-1400-S	
40' container loading:	16 sets
Welding lead code:	EF1-C7A
Water-tight lid only code:	OCH-1400-LW
Riser only code:	OCH-1400-RL
Deep base only code:	OCH-1400-BD
Set shipping weight (approx.):	92Kg (203 lbs)
Set shipping dimensions:	1410mm x 1410mm x 1080mm (55.5" x 55.5" x 42.5")
Shallow base only code:	OCH-1400-BS
Set shipping weight (approx.):	80Kg (176 lbs)
Set shipping dimensions:	1410mm x 1410mm x 860mm (55.5" x 55.5" x 33.9")

NOTE: Toggles OCH-1400-T included.

Optimum Chamber with Small Diameter Riser

Description	Product Code	Size (mm)	Pack Size	Weight (kg)	Weight (lbs)	Neck Opening	Overall Height (mm)
PE Chamber Deep/Small Bore	OCH-1400-DS	1400 x 1616	1	86	189	780mm	max = 1616 min = 1176
PE Chamber Shallow/Small Bore	OCH-1400-SS	1400 x 1266	1	80	176	780mm	max = 1266 min = 826



Full set code: OCH-1400-DS / OCH-1400-SS	
40' container loading:	16 sets
Welding lead code:	EF1-C7A
Water-tight lid only code:	LA-007-001
Riser only code:	OCH-1400-RS
Deep base only code:	OCH-1400-BD
Set shipping weight (approx.):	86Kg (189 lbs)
Set shipping dimensions:	1410mm x 1410mm x 1080mm (55.5" x 55.5" x 42.5")
Shallow base only code:	OCH-1400-BS
Set shipping weight (approx.):	80Kg (176 lbs)
Set shipping dimensions:	1410mm x 1410mm x 860mm (55.5" x 55.5" x 33.9")

NOTE: Toggles OCH-1400-T included.

Associated Items

Description	Product Code	Size (mm)	Pack Size	Weight (kg)	Weight (lbs)
PE Chamber Harness Assembly	OCH-1400-H	n/a	1	2.23	4.9
Spare Toggle for OCH Chambers Lids	OCH-1400-T	n/a	1	--	--
EF1 Welder Set 110V	EF1-110V	1 Full Kit	1	13.24	29.18
EF1 Welder Set 230V	EF1-230V	1 Full Kit	1	3.6	7.94



Advantages

- Easy installation.
- Integral pumped pressure supply.
- Small weather proof unit for discreet installation.
- One unit can service several pipe lines.
- Visual and audible alarm warnings.
- Complies with European Standard EN 13160.

Leak Detection Equipment

The UPP leak detection system monitors the interstitial space that runs the entire length of any UPP secondary contained pipework.

Using pressurised air or nitrogen, the system monitors the pressure within the interstitial space. Any reduction in pressure indicates a leak has occurred either in the primary or secondary pipe and a visual alarm is shown on the system's display screen. An optional external audible alarm will sound allowing the site operator to take the relevant pipelines out of service.

A pump housed inside the unit maintains the pressure in the system, meaning no external pressurised air or gas cylinders are required, reducing running costs for the operator.

It is possible to connect one unit to several double wall pipe lines on a site using manifolds (with individual line gauges for easy identification of leaking lines) or using interconnecting tubing.

The new LD-UPP-3 Leak Detector complies with the European standard EN 13160 and fulfils the highest environmental protection level.

Description	Product Code	Pack Size	Weight (kg)	Weight (lbs)
Leak Detector - Nitrogen Over Pressure	LD-UPP-2	1	1	2.20
Siren Acoustic Alarm	LD-SIGNAL HORN	1	2	4.41
Beacon Flashing Visual Alarm	LD-FLASHING LIGHT	1	2	4.41
IP55 Enclosure 400 x 600 x 200 mm	LD-PROTECTIVE BOX	1	--	--
Manifold - 2 UPP SC Lines	LD-MANIFOLD-2	1	2	4.41
Manifold - 4 UPP SC Lines	LD-MANIFOLD-4	1	4	8.82
Manifold - 6 UPP SC Lines	LD-MANIFOLD-6	1	6	13.23
Manifold - 8 UPP SC Lines	LD-MANIFOLD-8	1	8	17.64

Description	Product Code	Pack Size	Weight (kg)	Weight (lbs)
Leak Detector - Air Over Pressure	LD-UPP-3	1	8	17.64
Replacement Air Filter for LD-UPP-3	LD3-F	1	--	--
Manifold - 2 UPP SC Lines	LD3-M2	1	2	4.41
Manifold - 3 UPP SC Lines	LD3-M3	1	3	6.61
Manifold - 4 UPP SC Lines	LD3-M4	1	4	8.82
Manifold - 5 UPP SC Lines	LD3-M5	1	5	11.02

Caution

- This Leak Detector is not recommended for pipes with inner pipe made of plastic if liquids with flash points below 55°C are conveyed.
- Pumps and motor inside, pressurised air cylinder needed for mutual commissioning only.
- Air filter needed.



LD-UPP-2 Leak Detection



LD-UPP-3 Leak Detection

Dispenser Sumps Range

Our dispenser sumps, with patented welded entry boot and piping systems, give you what you need; years of worry-free, maintenance free performance.

All our UPP sumps are manufactured from virgin polyethylene with a steel painted frame and galvanised steel stabiliser bar and they are compatible with the UPP electrofusion entry system.



Large Mouth Sumps



DS 3617 ENCORE

Advantages

- Rigid and thick one-piece PE body with reinforced contoured structure.
- No Leak Paths - one system when using UPP Electrofusion(Elf) Entry Seals.
- Conduits can enter the dispenser through mounting frame without penetrating the sump wall.
- Integrated rain lip option.
- Large clear entry seal face.
- The PetroTite Ribbed Dispenser Sumps neck can be trimmed to adjust sump burial depth.
- Stabiliser bars feature pre-drilled shear valve mounting plate and spring channel nuts.



Compatibility Chart

Model	UPP Sump	Frame	Stabiliser Bar
Bennet			
3K Series	P0783, P0784, P0785, P0786, P0831, P0982, P0828, P0829, P0830, P0951	LM(M/D)-2010	Included SBK-2
Compaq			
Legend	MD6	LM(M/D)-4111	Included SBK-25
Dresser Wayne			
Vista™	3/V590D, 3/V591D, 3/V595D, 3/V490D, 3/V490D/U, 3/V590D/U, 3/V595D/U, 3/V399D, 3/V390D, 3/V390D/U, V395P/U, V590P/U, V590D/U, V395D/U, 1/V395D/U, 1/V590D/U, 1/V590D, X1/V590D, V395D, X/V395D, V590D, X/V590D	LM(M/D)-4111	Included SBK-25
Ovation™	R11, R13, B12/R22, B23	DS3915	Included DS-SB-15.1
Global Star	H Frame	DS4620	DS4620-F-WGHF DS-SBA-20
	CXX-11 1 product, CXX-21 2 product, CXX-31 3 product	DS3818	DS3818-F-CX31 DS-SBA-18
	CXX-44 4 product	DS5518	DS5518-F-CX44 DS-SBA-18
3/G Prefix	3/G2221D/GHK, 3/G2227D/GJKR, 3/G3387D, 3/G3388, 3/G3389D, 3/G3384D	LM(M/D)-2715	Included SBK-3
	3/G3397D, 3/G3399D, 3G/3390D, 3/G3490D, 3/G3498D	LM(M/D)-4115	Included SBK-3
Gilbarco™			
Encore™	550/500, 500S	DS3617	Included DS-SB17.1
SK700	2/1/2 - 2 hose	DS3420	DS3420-F-SK72 DS-SBA-20
	4/2/4 - 4 hose	DS3420	DS3420-F-SK74 DS-SBA-20
	6/3/6 - 6 hose	DS4620	DS4620-F-SK76 DS-SBA-20
	8/4/8 - 8 hose	DS4620	DS4620-F-SK78 DS-SBA-20
Advantage™	1 and 2 Grade	DS3017	Not Required DS-SB17
	3 and 4 Grade	LM(M/D)-4115	Included SBK-3
Neotec			
M-5200	M5225	LM(M/D)-2010	Included SBK-2
Somo			
Multi Ex	4S, 4S2H, 6S	LM(M/D)-4111	Included SBK-25
Tatsuno			
Neo Sunny	GDB-GSB 4 product models, GDB-GSB 3 product models, GDN-GSB 2 product models	LM(M/D)-4111	Included SBK-25
Sunny - X	3 product	LM(M/D)-4111	Included SBK-25
Multi - X	3 product	LM(M/D)-4111	Included SBK-25
Tokheim™			
Quantium™	410T	DS4620	DS4620-F-Q410 DS-SBA-20
	500T 2 product	DS3420	DS3420-F-Q5T2 DS-SBA-20
	500T 3 product	DS4620	DS4620-F-Q5T3 DS-SBA-20
	500T 4 product	DS4620	DS4620-F-Q5T4 DS-SBA-20
	500T 5 product*	DS5518	DS5518-F-Q5T5 DS-SBA-18

Note: Using the frame on the Gilbarco Encore 510 (1000/422 hole centres) will require modification to match up the hole centres.

Note: For "M/D" in part number use "M" for medium or "D" for deep when ordering.

Gilbarco™, Advantage™ and Encore™ are a trademarks of Gilbarco Inc.
Wayne™ is a trademark of Dresser Equipment Group Inc.
Quantum™, Ovation™ and Vista™ are a trademarks of Dresser Inc.
Tokheim™ is a trademark of Tokheim Holding B.V.

Large Mouth Dispenser Sumps



Description	Product Code	Pack Size	Weight (kg)	Weight (lbs)	Overall Base Dimensions (mm)
Medium/Deep Dispenser Sump 20" x 10"	LM(M/D)-2010	1	34.9	77	508 x 254
Medium/Deep Dispenser Sump 29" x 15"	LM(M/D)-2915	1	38.5	85	737 x 381
Medium/Deep Dispenser Sump 41" x 11"	LM(M/D)-4111	1	46.7	103	1042 x 280
Medium/Deep Dispenser Sump 41" x 15"	LM(M/D)-4115	1	50.3	111	1042 x 381



Description	Product Code	Pack Size	Weight (kg)	Weight (lbs)	Length (mm) *
Stabiliser Bar Kit for 2010	SBK-2	1	2.8	6.2	209 - 269
Stabiliser Bar Kit for 4111	SBK-25	1	2.9	6.3	343 - 514
Stabiliser Bar Kit for 2915 & 4115	SBK-3	1	3.3	7.4	257 - 352

* Measures to outside edge of the stabiliser bar kit.

PE Dispenser Sump for Wayne™ Ovation™

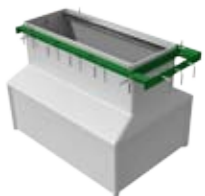

Description	Product Code	Pack Size	Weight (kg)	Weight (lbs)	Overall Base Dimensions (mm)
Deep Dispenser Sump 39" x 15" for Wayne™ Ovation™	DS3915	1	30	66.1	1031 x 719

Wayne™ is a trademark of Dresser Equipment Group Inc.
Ovation™ are a trademarks of Dresser Inc.



Description	Product Code	Pack Size	Weight (kg)	Weight (lbs)	Length (mm)
Stabiliser Bar Kit for DS3915	DS-SB15.1	1	3.1	6.8	325 x 102



PE Dispenser Sumps



Description	Product Code	Pack Size	Weight (kg)	Weight (lbs)	Overall Base Dimensions
Deep Dispenser Sump 36" x 17" for Gilbarco™ Encore™	DS3617 ENCORE	1	36.6	80.7	996 x 719

Gilbarco™ and Encore™ are a trademarks of Gilbarco Inc.



Description	Product Code	Pack Size	Weight (kg)	Weight (lbs)	Length (mm)
Stabiliser Bar Kit for DS3617	DS-SB17.1 ENCORE KIT	1	3.3	7.3	360 x 102



Description	Product Code	Pack Size	Weight (kg)	Weight (lbs)	Overall Base Dimensions
Deep Dispenser Sump 38" x 18"	DS3818	1	34.4	75.8	1034 x 880
Deep Dispenser Sump 55" x 18"	DS5518	1	42.4	93.5	1397 x 880



Description	Product Code	Pack Size	Weight (kg)	Weight (lbs)	Length (mm)
18" Wide Access Stabiliser Bar Kit	DS-SBA-18	1	4	8.8	483 x 140



Description	Product Code	Pack Size	Weight (kg)	Weight (lbs)	Overall Base Dimensions
PE Wide Access Sumps 34" x 20"	DS3420	1	27.7	61.1	967 x 742
PE Wide Access Sumps 46" x 20"	DS4620	1	32.6	71.9	1273 x 742



Description	Product Code	Pack Size	Weight (kg)	Weight (lbs)	Length (mm)
20" Wide Access Stabiliser Bar Kit	DS-SBA-20	1	4	8.8	496 x 140

Mounting Frame for Wide Access Dispenser Sumps



Description	Product Code	Pack Size	Weight (kg)	Weight (lbs)	Neck Opening
Gilbarco™ SK700 2 Hose Mounting Frame	DS3420-F-SK72	1	10	22.0	34" x 20"
Gilbarco™ SK700 4 Hose Mounting Frame	DS3420-F-SK74	1	10.7	23.6	34" x 20"
Gilbarco™ SK700 6 Hose Mounting Frame	DS4620-F-SK76	1	11	24.3	46" x 20"
Gilbarco™ SK700 8 Hose Mounting Frame	DS4620-F-SK78	1	14.4	31.7	46" x 20"
Gilbarco™ Encore™ 510 Mounting Frame	DS4620-F-Q410	1	11.8	26.0	46" x 20"

Gilbarco™ and Encore™ are trademarks of Gilbarco Inc.



Description	Product Code	Pack Size	Weight (kg)	Weight (lbs)	Neck Opening
Tokheim™ Q500 2 product Mounting Frame	DS3420-F-Q5T2	1	7.6	16.8	34" x 20"
Tokheim™ Q500 3 product Mounting Frame	DS4620-F-Q5T3	1	10.7	23.6	46" x 20"
Tokheim™ Q500 4 product Mounting Frame	DS4620-F-Q5T4	1	12.1	26.7	46" x 20"
Tokheim™ Q500 5 product Mounting Frame	DS5518-F-Q5T5	1	14.7	32.4	55" x 18"

Tokheim™ is a trademark of Tokheim Holding B.V.



Description	Product Code	Pack Size	Weight (kg)	Weight (lbs)	Neck Opening
Wayne™ CXX.11, 21, 31 Mounting Frame	DS3818-F-CX31	1	8.2	18.1	38" x 18"
Wayne™ Global Mounting Frame	DS4620-F-WGHF	1	12	26.5	46" x 20"
Wayne™ CX44 Mounting Frame	DS5518-F-CX44	1	12.8	28.2	55" x 18"

Wayne™ is a trademark of Dresser Equipment Group Inc.



Advantages

- Single and double poppet versions.
- Main poppet seals in valve body, preventing accidents when replacing adapters.
- Zinc plated body corrosion protection.
- Solid 3/8" test plug area prevents body from cracking if plug is over-tightened.
- 100% tested at 75psi.
- Fusible link closes poppet in the event of a fire (165°F / 74°C).

Materials

- Top: zinc plated cast iron.
- Body: zinc plated cast iron.
- Poppet: fluorocarbon.
- Carrier: zinc plated steel.
- Stem: stainless steel.
- Poppet spring: stainless steel.
- O-ring: fluorocarbon.
- Packing nut: brass.
- Inlet and outlet thread: 1-1/2".

EBW Shear Valves

EBW shut-off valves immediately stop product flow in the event of fire or collision at the dispenser. A patented top shears clean upon impact, causing the poppet to seal on the valve body preventing fuel spillage. When fire occurs, a fusible link releases the fulcrum arm, engaging the poppet. Standard 1-1/2" openings allow minimal flow restriction and a pre-drilled test plug is included for line pressure testing. The valve can be boss or U-bolt mounted. Easy-to-replace tops slide on and off valve base without lifting the dispenser. Tops are available in Male, Female or Union connections.

Single poppet models stop product flow from the pump. Double poppet models stop flow from the pump and dispenser piping.

Note: The closing feature of an automatic shut-off valve must be checked at least once per year by manually tripping and holding linkage.

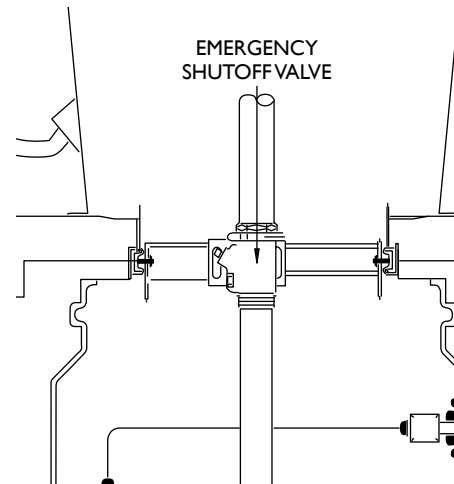

Female Top Models

Description	Product Code	Size	Poppet	Replacement Top	Thread
Shear Valve Single Poppet Female Top 1.5" NPT	662-410-02	1-1/2"	Single	662-118-02	NPT
Shear Valve Single Poppet Female Top 1.5" BSPT	662-420-22	1-1/2"	Single	662-128-12	BSPT
Shear Valve Double Poppet Female Top 1.5" BSPT	662-450-22	1-1/2"	Double	662-242-12	BSPT

Male Top Models

Description	Product Code	Size	Poppet	Replacement Top	Thread
Shear Valve Single Poppet Male Top 1.5" NPT	662-410-03	1-1/2"	Single	662-118-03	NPT
Shear Valve Single Poppet Male Top 1.5" BSPT	662-420-23	1-1/2"	Single	662-128-13	BSPT
Shear Valve Double Poppet Male Top 1.5" BSPT	662-450-23	1-1/2"	Double	662-242-12	BSPT

Union Top Models

Description	Product Code	Size	Poppet	Replacement Top	Thread
Shear Valve Single Poppet Union Top 1.5" NPT	662-410-01	1-1/2"	Single	662-118-01	NPT
Shear Valve Double Poppet Union Top 1.5" NPT	662-440-01	1-1/2"	Double	662-241-01	NPT

NFPA Warning

Annually test auto shut-off. Electrical supply to the submersible pump must always be disconnected before servicing meters, dispensers or emergency shut-off valves. Do not apply more than 50 psi to valve with poppet in its closed position. Valve seat and disc damage may occur.

Vapour Shear Valve



Description	Product Code
1" x 1-1/2" NPT thread vapour shear valve	362-206-03
Base thread includes 1-1/2" Female.	

Advantages

- Dual poppets seal vapours in dispenser riser and in vapour line for maximum environmental protection.
- One 1" test port and two 3/8" test ports eliminate extra T-joints in vapour line which reduces potential leak points and provides more flexibility for Stage II vapour recovery installation.
- Durable zinc plated body is resistant to corrosion.
- Standard U-bolt and boss mount allow for quick and easy installation.

Shear Valve U-bolt Kit

Holds the single or double poppet shut-off valve rigidly in place on the stabiliser bar, ensuring proper shearing.

Description	Product Code	Weight	
		Kg	Lbs.
Shear Valve U-Bolt Kit	662-138-01	0.14	0.30

Shear Valve Replacement Tops in BSP

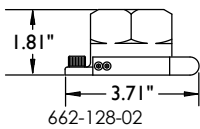

1-1/2" Female Replacement Adapter Models

Description	Product Code	Poppet	Shear Valve Adapter Used	Thread
Shear Valve Top Female 1.5" NPT	662-118-02	Single	662-410-07	NPT
Shear Valve Top Female 1.5" BSPT	662-128-02	Single	662-410-07	BSPT

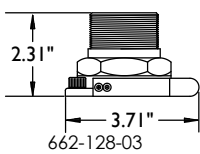

1-1/2" Male Replacement Adapter Models

Description	Product Code	Poppet	Shear Valve Adapter Used	Thread
Shear valve Top male 1.5" NPT	662-118-03	Single	662-410-08	NPT
Shear valve Top male 1.5" BSPT	662-128-03	Single	662-410-08	BSPT



Advantages

Integrity Confirmation

Always know how your spill containment is performing and get immediate confirmation on the integrity of the interstitial space with the following Defender Series features:

- I² (Interstitial Integrity) Monitor facilitates efficient monthly and annual visual inspections confirming the integrity of the secondary containment space.
- Electronic liquid detection sensor option available with proven ULS sensor for active leak detection.
- ULS wiring penetrates side wall of gravel guard ensuring no additional installation height requirement.

Fugitive Emission Protection

Proactively protecting a site from the dangers of fugitive emissions can save station owners both time and money by avoiding remediation due to fuel leakage. The Defender Series provides several key defences from these costly expenses:

- 1/4" compression gasket provides a vapour tight mechanical seal.
- Drop tube compression adapter ensures a vapour tight seal.
- Drain valve designed to meet CARB leak rate requirements.
- Concentrated secondary containment catch basin provides immediate notification of integrity breach.

Minimised Maintenance Costs

Maximise your business' value and minimise installation and maintenance expenses with features, such as:

- Field replaceable containment – replace easily without having to break concrete, simply loosen the four plough ring bolts to remove and replace interior containment.
- Plough ring bolts are protected – located inside the interior of the container, shielding them from the potential wear and tear of the forecourt environment.
- Variable height adjustments – allows for an installation height between 14 1/2" and 17 5/8", for easy installation in retrofit applications.

Defender Series™ Spill Container with I² Monitor

The Defender Series spill container combines years of knowledge and experience in forecourts across the globe to represent the next generation in spill containment. The Defender Series adapts alongside evolving environmental regulations with the latest innovations in spill containment. Get the best defence and quality construction with the Defender Series from Franklin Fueling Systems.



Monthly and annual visual inspections can be efficiently completed by inspecting the I² (Interstitial Integrity) Monitor to confirm liquid has not intruded into the secondary containment space. An electronic liquid detection sensor option is also available for site owners who choose to install active leak detection methods to further protect their investment.

The Defender Series double wall and single wall field replaceable spill container was designed with the retrofit application in mind. The variable height adjustment feature allows an installation height range of 14 1/2" to 17 5/8" which minimises the number of retrofit spill containment options needed to replace existing direct bury containments. This reduces the need to replace tank risers and ultimately reduces the retrofit installation time.

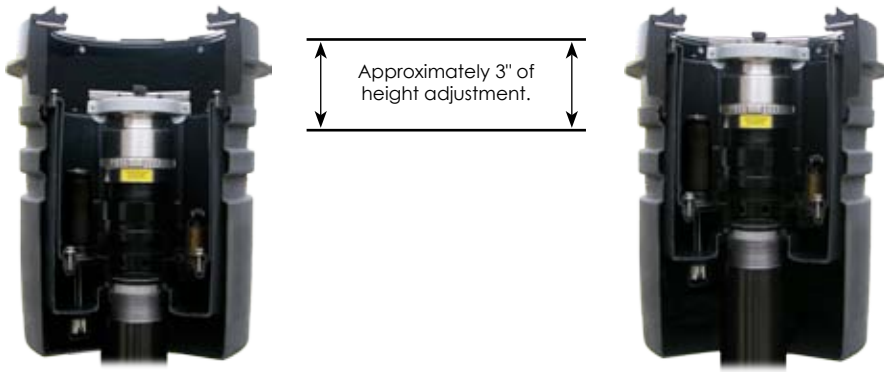

As regulations change, it may become necessary to upgrade a single wall spill container to meet future requirements. The Defender Series™ Spill Container allows the single wall option to be converted into a double wall spill container simply by removing the snow plough ring, removing the single wall containment, threading the secondary contained spill container onto the existing tank riser and then reinstalling the snow plough ring.

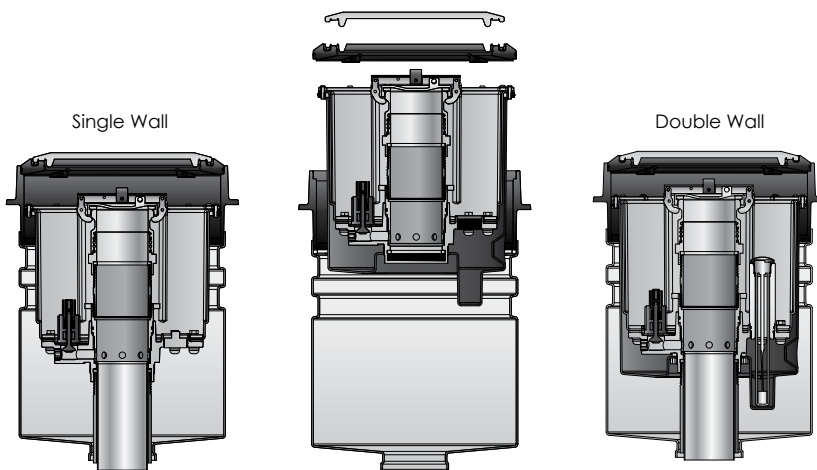

Model Number Reference Chart

705 XX X X X XXX
1 2 3 4 5

705 = Spill capacity and type

1 = Containment options

540 = Single wall 550 = Double wall

2 = Interstitial monitoring

0 = No sensor/gauge

1 = I² monitor (float gauge)

2 = TSP-ULS sensor

3 = Base thread

0 = NPT w/o riser, cap & adapter (RCA)

1 = NPT w/ RCA

2 = BSPT w/o RCA

3 = BSPT w/ RCA

4 = Drain Option

1 = With drain (pull)

2 = Without drain

5 = Lid option

Leave blank for NO cover

BLK = Black FRC WHT = White FRC

RED = Red FRC ORG = Orange FRC

BLU = Blue FRC BRN = Brown FRC

YEL = Yellow FRC ALUM = Aluminium

GRY = Grey FRC CI = Cast iron

CI-GKT = Cast iron w/ gasket

WHT-X = White FRC w/ black "X"

RED-X = Red FRC w/ white "X"

BLU-X = Blue FRC w/ white "X"

Description

Product Code

Single wall Spill Container 5 gal. with drain 4" NPT CI cover

705-540-001CI-GKT

Single wall Spill Container 5 gal. no drain 4" NPT CI cover

705-540-002CI-GKT

Description

Product Code

Double wall Spill Container 5 gal. with drain 4" NPT CI & I²

705-550-101CI-GKT

Double wall Spill Container 5 gal. no drain 4" NPT CI & I²

705-550-102CI-GKT

Double wall Spill Container 5 gal. with drain 4" NPT ULS sensor

705-550-201CI-GKT

Double wall Spill Container 5 gal. no drain 4" NPT ULS sensor

705-550-202CI-GKT



705



715



725

Composite Base Spill Containers

Description	Model, with drain	Capacity		Cover	Weight	
		Litre	Gallon		Kg	Lbs.
Spill Container 5 gal. 4" NPT composite base Black	705-471-01-BLK	19	5	Black, FRC, rain tight	19.30	42.00

Cast Iron Base Spill Containers

Description	Model, with drain	Capacity		Cover	Weight	
		Litre	Gallon		Kg	Lbs.
Spill Container 5 gal. 4" NPT CI base Black	705-470-01-BLK	19	5	Black, FRC, rain tight	25.00	54.00
Spill Container 5 gal. 4" BSPT CI base Black	705-470-21-BLK	19	5	Black, FRC, rain tight	25.00	54.00
Spill Container 5 gal. 4" NPT CI base Black Snap-On	705-472-01-BLK-S	19	5	Black, snap-on	25.00	54.00
Spill Container 5 gal. 4" NPT grey epoxy CI	705-479-65-CI-GKT	19	5	Grey epoxy coated cast iron w/gasket	25.40	56.00
Spill Container 5 gal. 4" NPT grey epoxy CI & RCA	705-479-01-CI-GKT	19	5	Grey epoxy coated cast iron w/ gasket, RCA *	25.40	56.00
Spill Container 5 gal. 4" NPT Rain Tight FRC Black	705-490-01-BLK	19	5	Black, FRC, rain tight	26.70	58.00
Spill Container 15 gal. 4" NPT Rain Tight FRC Black	715-470-01-BLK	57	15	Black, FRC, rain tight	28.00	62.00
Spill Container 25 gal. 4" NPT Rain Tight FRC Black	725-470-01-BLK	95	25	Black, FRC, rain tight	42.00	92.00

Description	Model, without drain	Capacity		Cover	Weight	
		Litre	Gallon		Kg	Lbs.
Spill Container 5 gal. 4" NPT Rain Tight FRC Black	705-458-01-BLK	19	5	Black, FRC, rain tight	29.40	64.00
Spill Container 5 gal. 4" NPT Rain Tight Black Snap	705-472-02-BLK-S	19	5	Black, snap-on	28.00	62.00
Spill Container 5 gal. 4" NPT grey epoxy CI & RCA	705-479-02-CI-GKT	19	5	Grey epoxy coated cast iron w/gasket, RCA *	30.80	68.00
Spill Container 5 gal. 4" NPT CI base FRC Black	705-490-02-BLK	19	5	Black, FRC, rain tight	19.30	42.00
Spill Container 5 gal. 4" NPT CI base Black Snap-On	715-472-02-BLK-S	57	15	Black, snap-on	28.00	62.00

* RCA = With Riser, Cap and Adapter

Grade Level Spill Container Accessories and Replacement Parts

Rain tight Cover Options

Suffix	Description
BLK	Black, rain tight
WHT	White, rain tight
RED	Red, rain tight
BLU	Blue, rain tight
YEL	Yellow, rain tight
GRY	Grey, rain tight
ORG	Orange, rain tight
GRN	Green, rain tight
BRN	Brown, rain tight
WHT-X	White, rain tight with black cross
RED-X	Red, rain tight with white cross
BLU-X	Blue, rain tight with white cross
ALUM	Aluminium
CI	Cast iron
CI-GKT	Cast iron with gasket
WATERT	Watertight aluminium



Watertight aluminium lock-down cover

Note: You must specify cover option at time of order.

12" Replacement Covers For Grade Level Spill Containers

Description	Product Code
Replacement Clips for Snap-On covers	705-171-01
Spill Containment Cover - Black FRC Snap-On	705-333-01*
Spill Containment Cover - Aluminium	705-409-00
Spill Containment Cover - White & Black Cross	705-420-02
Spill Containment Cover - Red & White Cross	705-420-03
Spill Containment Cover - Blue & White Cross	705-420-04
Spill Containment Cover - Black FRC	705-423-01
Spill Containment Cover - White FRC	705-423-02
Spill Containment Cover - Red FRC	705-423-03
Spill Containment Cover - Blue FRC	705-423-04
Spill Containment Cover - Yellow FRC	705-423-05
Spill Containment Cover - Orange FRC	705-423-07
Spill Containment Cover - Green FRC	705-423-08
Spill Containment Cover - Bronze FRC	705-423-09
Spill Containment Cover - Cast Iron	705-430-00
Spill Containment Cover - Cast Iron with Gasket	705-440-01
Spill Containment Cover - Aluminium Watertight **	710-430-01

* Snap-on lids fit only on special snap-on spill containers. Please consult Customer Services. Minimum quantities may apply.

** Aluminium watertight for use on 705, 715 and 725 grade level spill containers.



Advantages

- Constructed of anodised aluminium or brass body.
- Fits all 4" vapour recovery hoses.

4" Vapour Check Valve Adapter



Product Code	Hose Size	Riser Thread	Height		Body Material	Weight	
			mm	In.		Kg	Lbs.
300-300-01	4"	3" NPT	139	5.44	Anodised aluminium	1.95	4.30
300-300-31*	4"	3" BSP	139	5.44	Anodised aluminium	1.95	4.30
300-210-01	4"	4" NPT	107	4.19	Anodised aluminium	1.95	4.30
300-210-31*	4"	4" BSP	107	4.19	Anodised aluminium	1.95	4.30

Product Code	Description
770-201-02	3" replacement gasket for 300-300
770-201-03	4" replacement gasket for 300-210

* BSPT thread on the 300-300-31 and 300-210-31, NPT thread on others.

Advantages

- Two body styles to choose from: glass filled nylon and epoxy.
- Coated aluminium.
- Padlock capability.
- Iron-copper infiltrated 4" cams.
- Corrosion resistant steel latches.
- Orange body for easy identification.
- Construction is cast brass and stainless steel for long life.

4" Vapour Adapter Cap



Product Code	Material	Weight	
		Kg	Lbs.
304-200-01	Glass filled nylon	0.53	1.19
304-301-01	Epoxy coated aluminium	0.63	1.38

Product Code	Description
777-111-01	Replacement gasket for 304-200-01
950-215-01	Replacement gasket for 304-301-01

2" Ball Float Advantages

- Epoxy coated steel nipple to prevent dissimilar metals from contacting each other.
- Stainless steel ball float is corrosion resistant for long life.

2" Ball Float Vent Valves



Product Code	Length		Bleed Hole		Weight	
	mm	In.	mm	In.	Kg	Lbs.
308-205-01	178.00	7.00	2	0.06	1.36	3
308-205-21 *	178.00	7.00	2	0.06	1.36	3

* BSPT thread on the 308-205-21.

3" Float Vent Valves



Description	Product Code
3" x 3" x 2" BSP for manifolded vents SS ball. Aluminium	305-305-21

Top Seal Fill Pipe Adapter



Product Code	Height		Description	Weight		Thread
	mm	In.		Kg	Lbs.	
780-200-01	44.45	1.75	3" without lugs	0.90	2	NPT
780-200-31	44.45	1.75	3" without lugs	0.90	2	BSPP
778-302-31	57.15	2.25	3" with lugs	0.90	2	BSPP
778-301-01	68.27	2.69	4" with lugs	0.90	2	NPT
778-301-35	68.27	2.69	4" with lugs - nickel plated	0.90	2	BSPP
778-301-32	68.27	2.69	4" without lugs	0.90	2	BSPP
Product Code	Description					
770-201-02	3" replacement gasket					
770-201-03	4" replacement gasket					

Advantages

- Constructed of ASTM B62 corrosion resistant bronze.
- Nitrile gasket for a secure seal onto the fill pipe.

3" Top Seal Fill Caps



Description	Product Code	Weight	
		Kg	Lbs.
Fill Cap 3" Aluminium lockable	779-200-01	0.45	1
Fill Cap Replacement Gasket 3"	774-202-03	--	--

Advantages

- Extruded brass cam arm.
- Cap body made of corrosion resistant epoxy coated aluminium.

4" Top Seal Fill Caps



Description	Product Code	Weight	
		Kg	Lbs.
Fill Cap 4" Nylon Biofuel approved	777-201-02*	0.45	1
Fill Cap Replacement Gasket 4"	950-215-01	--	--

*Biofuel approved model (E85 and biodiesel), CARB: Phase 1 Certification VR-101.

Note: 777-201-02 replaces 777-201-01

Advantages

- Glass-filled nylon and aluminium body styles available.
- Stainless steel latches.
- Padlock capability.
- Form fitting replaceable gasket, molds itself to the contour of the adapter to form a positive seal for added protection.

4" Product Delivery Elbow



Description	Product Code	Weight	
		Kg	Lbs.
Product Delivery Elbow 4" Cam & Groove with Sight Glass	880-445-01	7.26	16

Advantages

- Cast iron covers are resistant to chemical corrosion from petroleum and alcohols.
- Extremely hard wearing and durable, they will not spin out, buckle or lose shape due to pressure forces from vehicles and are highly resistant to chemical corrosion.
- BS EN 124 to Class D400 structural integrity as tested by Lloyds British Testing plc.
- Lockable design provides increased on-site security and safety.
- When locked the covers become completely watertight thanks to a special chemically resistant neoprene sealing gasket and internal drainage channel.

UPP Access Covers

The patented PetroTite PowerLift cast iron access covers and PCC90 composite access covers provide maximum durability for high traffic areas while also allowing easy access to tank chambers. By combining the strength and durability of cast iron with easy-to-handle composite material covers, UPP Access Covers provide superior performance yet remain light and easy to operate.

The clever spring loaded hinge mechanism on the PetroTite PowerLift allows the covers to be opened and closed with ease using a lightweight handle and also stay open at any angle without the need for a locking mechanisms or stays. The covers are therefore easily opened and closed by operators without the risk of injury.

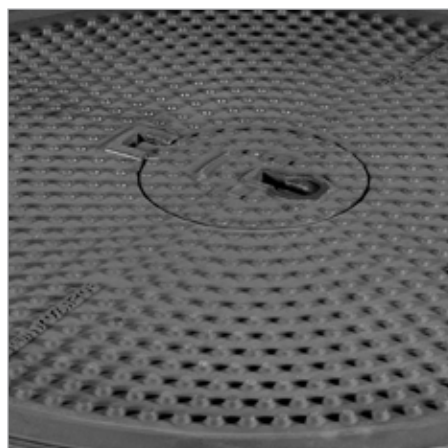
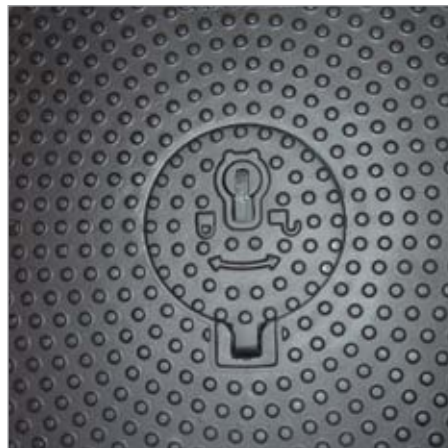

UPP Access Covers



Description	Product Code	Pack Size	Kg	Lbs.	Size (mm)
UPP Access Cover 760x760mm D400 flush	PC76-D400	1	120	264.6	760 x 760



Description	Product Code	Pack Size	Kg	Lbs.	Size (mm)
UPP Cast Iron Cover 760x760mm raised	PC76-1	1	121	266.8	760 x 760



Description	Product Code	Pack Size	Kg	Lbs.	Size (mm)
UPP Cast Iron Cover 770x770mm raised	PC77 *	1	130	286.6	770 x 770

* Note that one handle PC76/H comes free with each PC77 cover.



Description	Product Code	Pack Size	Kg	Lbs.	Size (mm)
UPP Access Cover 950mm Dia D400	PC95-D400	1	200	441	1300 X 1200



Description	Product Code	Pack Size	Kg	Lbs.	Size (mm)
UPP Cover 950mm Dia Dip D400	PC95-D400-DIP	1	200	441	1300 X 1200



Description	Product Code	Pack Size	Kg	Lbs.	Size (mm)
UPP Cast Iron Cover 1500 x 760mm D400	PC-150-76-D400	1	264	582	1502 X 762



Description	Product Code	Pack Size	Kg	Lbs.	Material
Handle for PC 51/76/77/95 (pictured)	PC76/H	1	1.06	2.3	Cast Iron
Gasket for PC76 Access Cover	PC76/J	1	0.3	0.7	Neoprene



Description	Product Code	Unit	Kg	Lbs.	Size (mm)
Composite Cover 900mm	PCC90	1	66.5	146.6	Ø900
Fibreglass Skirt for PCC90	PCC90-SK	1	6.36	14.0	Ø900



Description	Product Code	Pack Size	Kg	Lbs.	Material
Composite Cover Lifting Handle	PCC-H	1	6.5	14.3	Galvanised Steel

Ancillary Items

Description	Product Code	Pack Size	Kg	Lbs.	Material
Gasket for PCC90 Access Cover	PCC-J	1	n/a	n/a	EPDM



Advantages

- Cast Iron Cover and Skirts - EBW 7-1/2" round access covers have ribbed cast iron covers and cast iron skirts to withstand heavy loads and traffic.
- Heavy Duty Skirts - EBW 12" and 18" round access covers have a 16 gauge welded steel skirt and are available in different depths to fit your needs.
- Coloured Cover Options - EBW 18" round access covers can be ordered with optional FRC coloured covers in standard API colour codes. The FRC covers also include a recessed area for optional API colour coded identification plates.
- Highway 20 Rated (D.O.T. H20) - All EBW spill containers and access covers exceeded the D.O.T. H20 requirement.

Composite Access Cover Advantages

- Exceeds D.O.T. Requirements - Engineered for high-strength and tested to over 50,000 lbs. load (2-1/2 times D.O.T. requirement) without failure.
- Fatigue Resistant - Product has undergone 30 year life simulation testing, with 11,000 loading cycles of 20,000 lbs. each.
- Lightweight - FRC composite covers weigh almost one-third less than steel. Lighter weight reduces back injuries, increases ease of access to access pit and decreases shipping costs.
- Skirt Ring - Made of 1/4" rolled angle iron. Skirt is 14 gauge steel, built to handle the heaviest traffic.
- Slide Action Cover - Cover is removed and replaced by placing the slide action handle into the plate on the cover. No bending down to remove the cover.
- Cover Options - Bolted, non-bolted and slide on models. All covers are supplied with handles.
- Optional Aramid Covers - For extra wear protection at heavy traffic sites. Available for 36" and 42" models only.

Round Access Covers & Skirts

These access covers have a proven track record of trouble-free operation. Their durable construction withstands the heaviest traffic and meets the requirements of a D.O.T. H20 load rating.



7-1/2"



12"



18"

Description	Product Code	Access Pit Size		Skirt Depth		Weight	
		mm	In.	mm	In.	Kg	Lbs.
7.5" Cast Iron Access Covers and Skirt	781-208-08	191	7.5	203	8	10	22
12" Cast Iron Access Cover and Steel Skirt	781-212-12-CI	305	12	305	12	16	36
12" Cast Iron Access Cover and Steel Skirt + Handle	781-212-12-CI-H	305	12	305	12.	16	36
18" Composite Cover and Steel Skirt - Black Cover	781-418-18-BLK	457	18	457	18	18	39

Replacement Round Access Covers

Description	Product Code, with drain	Access Pit Size		Weight	
		mm	In.	Kg	Lbs.
7.5" Cast Iron Cover only	781-402-01	191	7.5	3	6
12" FRC Cover only - Black	781-302-01	305	12	5	10
12" FRC Cover only - Orange	781-302-07	305	12	5	10
12" Cast Iron Cover only	781-400-01	305	12	8	17
12" Cast Iron Cover + Handle	781-407-01	305	12	8.1	18
18" FRC Cover only - Black	781-304-01	457	18	5	10
18" Steel Cover only	781-306-01	457	18	15	33
18" Steel Cover only - Bolt Down	SRC18HRP	457	18	15	33

36" Fibre Reinforced Composite Access Covers

EBW SAFE-LITE FRC manway covers are ultra-lightweight. Engineered and tested to exceed the D.O.T. H20 load ratings. Covers weigh almost one-third less than steel which dramatically reduces injury potential during cover removal. The slide action cover further reduces the chance of injury by eliminating the need to bend down to remove or replace the cover.



Description	Product Code	Cover OD
36" Access Cover - Slide Action, Grey	781-482-06	39.5"
Handle for Slide Action Cover Removal	781-341-01	--

Monitoring Well Caps



Description	Product Code	Size	
		mm	In.
Monitoring Well Cap 2"	772-106-01	51	2
Monitoring Well Cap 4"	772-102-01	102	4
Monitoring Well Cap 6"	772-109-01	152	6

Monitoring Well Screen Pipe

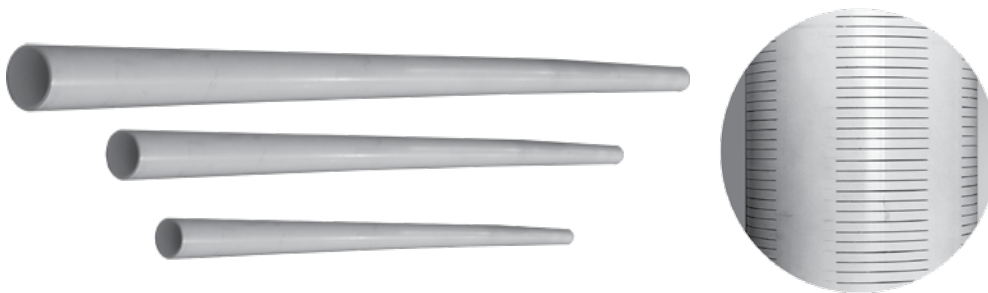

Description	Product Code	Size		Length		Weight	
		mm	In.	cm	Ft.	Kg	Lbs.
Monitoring Well Screen Pipe 2' x 13'	773-200-01	51	2	396	13	7	15
Monitoring Well Screen Pipe 4' x 13'	773-200-02	102	4	396	13	12	27
Monitoring Well Screen Pipe 4' x 13' Heavy Duty	773-200-04	102	4	396	13	14	31
Monitoring Well Screen Pipe 6' x 15'	773-200-03	152	6	457	15	21	47

Monitoring Well Covers



Description	Model	Size		Weight	
		mm	In.	Kg	Lbs.
Monitoring Well Cover and Skirt Cast Iron 8"	808-400-01	203	8	8	18
Monitoring Well Cover and Skirt Cast Iron 10"	810-302-01	254	10	11	25
Monitoring Well Cover and Skirt Cast Iron 14"	814-302-01	356	14	19	41



Advantages

- Hydrostatic pressure adjusting mechanism with durable weather cap.
- Built in thermal expansion pressure relief valve.
- 1.5" and 2" models are ideal for fuel oil and generator applications.
- Can be installed in horizontal or vertical position.
- Can be used in pressure systems.

Anti Syphon Valves



Description	Product Code	Size		Head Pressure Range	Weight	
		mm	In.		Kg	Lbs.
Anti-Syphon Valve 1.5" NPT	616-300-02	38.10	1.50	12' to 25'	2.09	4.60
Anti-Syphon Valve 2" NPT	636-300-01	50.80	2.00	5' to 12'	3.27	7.20

NFPA 30.
API/RP 2000.

Advantages

- Cylindrical float design eliminates interference with tank walls and cross braces.
- 100 psi working pressure rating.
- Flow rate 200 gpm at 20 psi.
- No minimum flow rate.
- Ships complete with upper nipple and Tight Fill adapter with crossbar to prevent open fills.
- Simply thread onto a 4" riser pipe to install. Length of upper tube determines shut-off point.

Warden® AST Overfill Prevention Valve



Description	Product Code	Weight	
		Kg	Lbs.
Warden Overfill Prevention Valve for AST 4" NPT	709-420-01	5.67	12.50
3" Dust Cap for Warden AST OPV	774-212-30	--	--

Advantages

- Dome-shaped top drains off moisture including rain, snow and ice.
- 30 mesh prevents dirt and debris from entering vent lines.
- Screw fixing.

Tank Vents



Description	Product Code	Size In.	Weight	
			Kg	Lbs.
Vent Cap Aluminium Upward Discharge 2" Screw Fixing	800-207-02	2	0.42	1.00
Vent Cap Aluminium Upward Discharge 3" Screw Fixing	800-203-01	3	0.54	1.19



Description	Product Code	Pack Size	Kg	Lbs.

Advantages

- Two model types available, NPT/BSPT threads or O-ring with locking screw.
- NFPA 30.

Pressure Vacuum Vents



Description	Product Code	Size In.	Weight	
			Kg	Lbs.
PV Valve Aluminium Upward Discharge 2" NPT	802-303-01*	2	0.85	1.88
PV Valve Aluminium Upward Discharge 2" BSP	802-303-21*	2	0.85	1.88
PV Valve Aluminium Upward Discharge 2" Screw Fixing	802-303-02*	2	0.83	1.84

*UL file # MH 15882.

3/4" Safety-Sever™ Breakaway



Product Code	Size In.	Weight	
		Kg	Lbs.
697-137-01	0.75	0.04	0.88
698-133-21 *	0.75	0.04	0.88
Product Code	Description		
697-133-01	Replacement set screws		
699-200-01	3/4" hose		

* BSP thread on 698-133-21. NPT thread on 697-137-01

Advantages

- Standard 3/4" NPT fittings.
- Uncouples instantly.
- Self-contained.
- Instantly seals both sides of the break.
- Seals are engineered for standard and biofuels.

1" Safety-Sever™ Breakaway



Product Code	Size In.	Weight	
		Kg	Lbs.
797-225-01	1	0.50	1.00
Product Code	Description		
797-133-01	Sever screw		
699-200-02	1" hose		

Advantages

- Standard 1" NPT fittings.
- Uncouples instantly.
- Self-contained.
- Instantly seals both sides of the break.
- Seals are engineered for standard and biofuels.

2" NPT Angle Check Valves



Product Code	Size In.	Poppet Type	Weight	
			Kg	Lbs.
635-201-01	2	Single	3.30	7.25

1.5" Union Check Valve



Product Code	Size In.	Screen	Weight	
			Kg	Lbs.
650-108-02	1.50	No	0.23	0.50
650-104-02	1.50	Yes	0.23	0.50

Advantages

- Spring-loaded poppet.
- Open construction design allows for free flow of product.
- With or without protective screen.



Advantages

- Two-stage, spring-loaded shut-off flapper reduces line shock.
- Vertical float design allows for valve to be removed even when tank is full.
- Inspection test port.
- Bottom tube threads on.

Installation

- The AutoLimiter® II is designed solely for use in underground storage tanks. For gravity drops only. No attempt should be made to utilise this product with aboveground storage tanks. The valve would not function, creating a very dangerous condition.
- EVR Phase 1 models require T-6100-FT installation tool.

AutoLimiter® II Automatic Overfill Prevention Valve

The AutoLimiter® overfill prevention valve is a self contained two-stage positive shut-off valve designed to prevent the overfill of an underground storage tank (UST) during a gravity product delivery. When the liquid level of the UST reaches about 92% of the tank capacity during a fill, the product in the tank raises the lower float of the valve. The primary poppet of the valve is then released and reduces flow to about 10% of normal flow. The sudden reduction in flow created by the closing of the primary poppet provides "line shock" to the fill hose notifying the delivery driver the tank is nearing 95% capacity. The delivery driver can then stop filling the tank, disconnect and drain the delivery hose. The upper float will close off the product flow when the product level reaches 95% of the tank capacity.

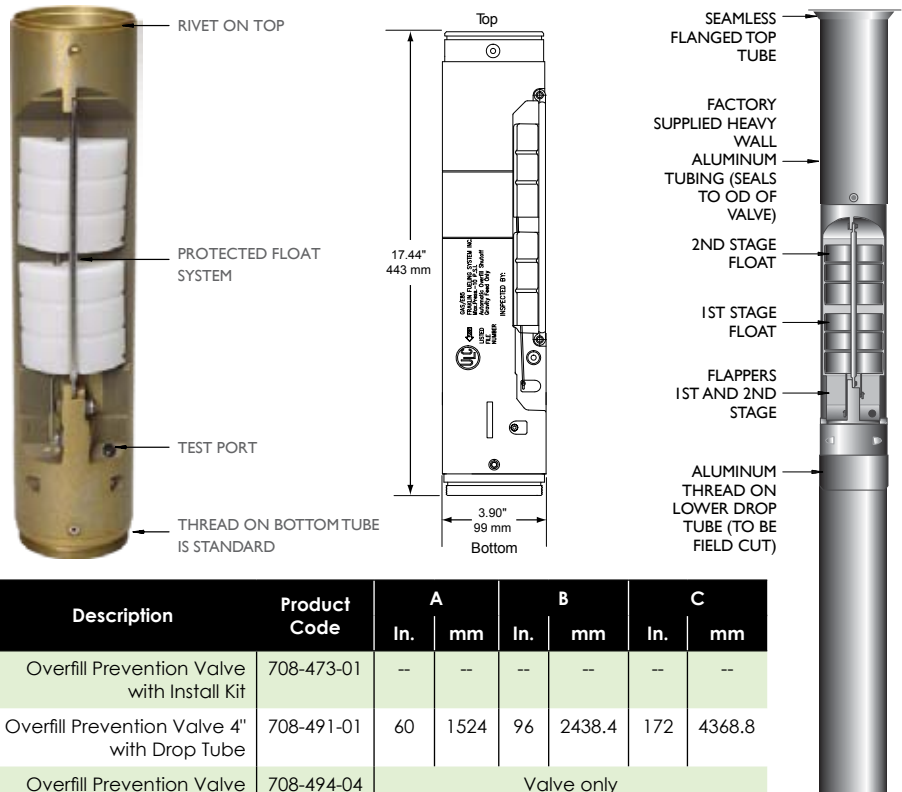

Description	Product Code	A		B		C	
		In.	mm	In.	mm	In.	mm
Overfill Prevention Valve with Install Kit	708-473-01	--	--	--	--	--	--
Overfill Prevention Valve 4" with Drop Tube	708-491-01	60	1524	96	2438.4	172	4368.8
Overfill Prevention Valve only 4" without Drop Tube	708-494-04	Valve only					

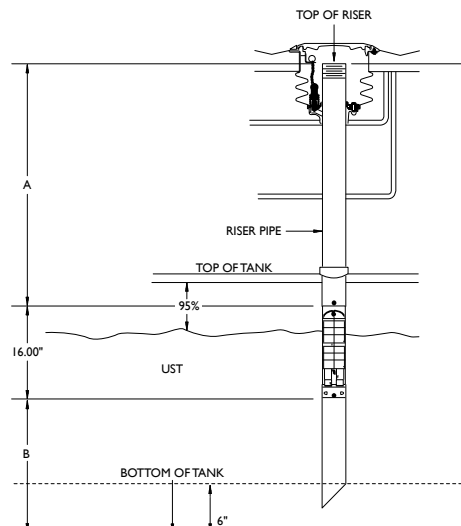

Drop Tubes

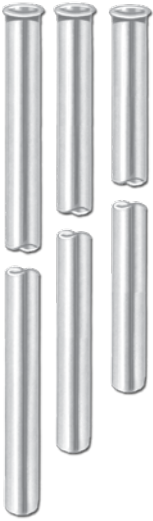

EBW drop tubes are available in two wall thicknesses. The thin wall (.035 thickness) models offer easy handling and installation. The heavy wall (.062 thickness) models offer more durability. The drop tube fits directly into the underground tank. Fuel is efficiently delivered at a faster rate, and ensures submerged filling, which generates less vapours and evaporation. The drop tubes are furnished with a straight cut bottom, which can be cut to length on the job site.

Description	Product Code	Tubes per Box	Size		Wall Thickness		OD		Weight	
			mm × M	In. × Ft.	mm	In.	mm	In.	Kg	Lbs.
Drop Tube, Aluminium 4" x 10' Pack of 2	782-204-10-2	2	102 × 3.05	4 × 10	1.580	0.062	99	3.88	10	22

LAG14 Leak Detection

This class II (EN 13160-1: 2003) leak detector with an intrinsically safe probe circuit is designed for double-skinned tanks containing liquid in the interstitial space. The unit is designed for monitoring inflammable liquids of danger classes A I, A II, A III and B stored above ground and non-inflammable water-polluting liquids.

The system consists of a control unit, a container for leak monitoring fluid and a probe. CE-certified control unit with visual and audible alarms, test button and increased interference protection. With relay for connection of additional alarm equipment.



Description	Product Code	Pack Size	Weight (kg)	Weight (lbs)
Leak detector for double-skinned tanks	LAG14-ER	1	1.4	3.1



Advantages

- The EF1 welder is IP65 rated and has been tested around the world under exacting site conditions and has proved to be an easy to use, efficient and invaluable addition to the tool box. Its robust construction, dust proof features and enhanced graphic feed-back of the electrofusion progress, offer real benefit to the operator.
- The unit's improved self diagnostic capabilities also ensure increased reliability and tolerance in a variety of climatic conditions. It comes complete with welding leads in a lightweight carry bag for the 230V and a robust case for the 110V.
- The EF1 unit automatically recognises the fitting when connected with the correct welding cable. It also checks the ambient temperature using a sensor positioned in the housing and adjusts the energy level to balance with the local environment. It then applies the correct amount of energy for a successful weld.

230V & 110V EF1 Welder

The EF1 UPP electrofusion unit from Franklin Fueling Systems works with all UPP electrofusion fittings and products.

UPP welders feature state-of-the-art electronics which allow for a more compact, user-friendly design.



EF1 230V Handheld Welder

EF1 110V Encased Welder

Welding Unit Specifications		
UPP Stock Code Number	EF1-230V	EF1-110V
Operating Voltage	230V AC Supply	110V AC Supply
Operating Frequency	45 to 65Hz	
Operating Temperature	-15° to 45°C (5°F to 113°F)	
Shipping Dimensions	460mm x 210mm x 210mm	420mm x 340mm x 80mm
Shipping Weight	3.6Kg (7.9lb)	13.24 Kg (29.18lb)

Description	Product Code	Pack Size	Kg	Lbs.	Colour
EF1 Welder Set 110V	EF1-110V	1 Full Kit	13.24	29.18	Orange
EF1 Welder Set 230V	EF1-230V	1 Full Kit	3.6	7.94	Orange

CE Certified			
Supplied Cables			
Primary Cable - Standard	Red	4mm	5.5m long
Secondary Containment Cable	Green	2mm	5.5m long
Bridging Cable (For multiple welds)	Red	4mm	5.5m long
Fusion Chamber Cable	White	2.3mm	5.5m long
Power Supply Cable		4m (13')	

Cables & Transformer

Description	Product Code	Pack Size	Kg	Lbs.	Colour
Welding Cable - Primary 4amp, 4mm Pins Red	EF1-PC 4MM	1	0.48	1.06	Orange / Red
Welding Cable - Secondary 5amp, 2mm Pins Green	EF1-SC 2MM	1	0.48	1.06	Green
Welding Cable - Chamber 7amp White	EF1-C7A	1	0.48	1.06	White
Welding Cable - Primary 2mm Red	EF1-PC 2MM	1	0.48	1.06	Orange / Red
Bridging Cable - Primary 4amp, 4mm Pins Red	EF1-BC 4MM	1	0.02	0.04	Orange / Red
Welding Cable - Secondary for E3, E4 & E7 welders only Green	EW/BC/SC	1	0.5	1.10	Green
Welding Cable - Primary 2mm for E3, E4 & E7 welders only Red	EW1/C	1	0.44	0.97	Orange
Welding Transformer 115v In ~ 230V Out	EW/TRANS/3.3KVA	1	18.96	41.81	Blue

This unit is designed to weld UPP pipes and fittings only* and must not be used in conjunction with any other Polyethylene pipework systems.

*The UPP systems welder uses a constant current welding system unlike other systems which use constant voltage. Non-UPP fittings may not be fused correctly with a risk of leakage. Information shown is accurate at the time of going to print. Franklin Fueling Systems reserves the right to change product specifications at any time.

Vacuum Tightness Testing Kit

The System Integrity Testing Kit from Franklin Fueling Systems allows tightness testing of spill containers, tank access chambers and dispenser sumps to ensure air-tight seals and peace of mind. Specific testing at critical points during the installation process ensures that all components are installed correctly and that the complete installation is leak proof, preventing the need for an expensive rework.

- Easy to use.
- Clear and concise instructions.
- Easy to read vacuum gauge.
- Adjustable depth of test to match water table level.
- Built-in spark arrester.
- Appropriate for use on a variety of systems.
- Variety of test lids available with carry bags.



Description	Product Code	Pack Size	Kg	Lbs.
Vacuum Testing Unit 110V	VTU-110V	1	17.5	38.58
Vacuum Testing Unit 230V	VTU-230V	1	17.5	38.58

Description	Product Code	Pack Size	Kg	Lbs.
Chamber Test Lid Assy 560 dia	VTL-560 DIA	1	3	6.6
Chamber Test Lid Assy 1200 dia	VTL-1200 DIA	1	15.5	34.17
Chamber Test Lid Assy 1350 dia	VTL-1350 DIA	1	21	46.2
Sump Test Lid Assy 800x800	VTL-800x800	1	9	19.84
Sump Test Lid Assy 1250x600	VTL-1250X600	1	11	24.25
Sump Test Lid Assy 1470x600	VTL-1470X600	1	14	30.8

Advantages

- A Vacuum test unit which can be set to indicate the relationship between the on-site water table level and the level of the tank or dispenser sumps. The pressure test setting allows for low pressure testing with an additional setting specifically for spill containers.
- 5.5 metre connection tubes between the test unit and the test lid allow the test unit to be placed outside zone 2 areas during testing.
- Transparent test lids (sold separately) with close cell foam gaskets are available in a variety of sizes. These allow full visibility of areas being tested to observe gaskets, penetration seals etc. for easy visual identification of leak points. All lids come supplied in a tough black carry bag.

90 Series Fittings Tools



Pit Spanner



Chain Wrench

Description	Product Code	Unit	Kg	Lbs.	Material
Pit Spanner 50A/F 91-050	91-050-TOOL	1	0.8	1.7	All Male 50mm sizes
Pit Spanner 55A/F 92-050	92-050-TOOL	1	0.9	1.9	All Female 50mm sizes
Pit Spanner 62A/F 91-063	91-063-TOOL	1	1.1	2.4	All Male 63mm sizes
Pit Spanner 67A/F 92-063	92-063-TOOL	1	1.2	2.6	All Female 63mm sizes
Chain Wrench 125mm Pipe Max	CW-125-PIPE	1	1.2	2.6	All Male and Female 90 and 110mm sizes

shown with 90 series as an exMPLE

UPP Tool Box

Description	Product Code	Pack Size	Kg	Lbs.	Colour	Item Type
Tool Box UPP with Tools No Welder - please order separately	IB 1000 (EX EW)	1 Full Kit	58	127.87	Black	Misc
Contents:						
Rotary Scraper 25-110mm 1 - 4"	SCR-025-110	1				
Pipe Cutter 50 - 125mm Pipe	P.CUT	1				
Cutting Wheel for P.CUT Pipe Cutter	CW1	1				
Holesaw 140mm for 305 Entry Seal	HS5	1				
Holesaw 210mm for 308 Entry Seal	HS8	1				
Holesaw 83mm for PS3	HSP3	1				
Holesaw 168mm for PS6	HSP6	1				
Mandrel for All Holesaws	MAN1	1				
Angled Clamp for straight & elbow joints	CLAMP (A)	1				
Straight Clamp for straight joints (32 - 110mm)	CLAMP (S)	2				
Clamp for 305 Extended Entry Seal	305-CLAMP-1	2				
Clamp for 308 & 308-075 Entry Seals	308-CLAMP	1				
Mallet	MAL1	1				
Flexishaft Driver	F.DRIVER	1				
Hand Held Scraper 1 1/2"	SCR.HAR	1				
Blades for Hand Held Scraper (8 Blades)	SCR.HAR(B)	1				
Pipe Marker Pen	MARKER	1				
UPP Installation Manual	-	1				



Pipe Cutters



Description	Product Code	Unit	Kg	Lbs.	Material
UPP Pipe Cutter 32 - 50mm	P.CUT SMALL	1	0.76	1.68	Aluminium & Steel
Cutting Wheel for P.CUT SMALL	CW2	1	0.005	0.01	Steel
UPP Pipe Cutter 50 - 110mm	P.CUT	1	1.84	4.05	Aluminium & Steel
UPP Pipe Cutter 110 - 160mm	P.CUT MED	1	2.19	4.82	Aluminium & Steel
Cutting Wheel for P.CUT & P.CUT MED	CW1	1	0.016	0.04	Steel

Rotary Scraper



Description	Product Code	Unit	Kg	Lbs.	Material
UPP Rotary Scraper 25-110mm 1" - 4"	SCR-025-110	1	1.48	3.26	Aluminium & Steel
UPP Rotary Scraper 90-225mm 3" - 9"	SCR-090-225	1	3.57	7.87	Aluminium & Steel
UPP Rotary Scraper Spare Blade 1" - 9"	SCR-BLADE-025-225	1	0.01	0.02	Steel

Hand Held Scraper



Description	Product Code	Unit	Kg	Lbs.	Material
UPP Hand Scraper	SCR.HAR	1	0.08	0.18	Plastic & Steel
Blades for SCR.HAR (8 Blades)	SCR.HAR(B)	2	0.04	0.09	Steel

Scraper Kit



Description	Product Code	Pack Size	Kg	Lbs.
Upgrade Kit for Legacy Scraper 50mm	SCR-50MM-UG-KIT	1	0.52	1.15
Scraper Kit for Legacy UPP 50/63/90/110mm	SCR.K(1)	1	4.98	10.98
Replacement Blade for SCR.K(1) Shallow Cut	SCR.B	1	0.014	0.03
Scraper Kit for current UPP 50/63/90/110mm	SCR.K(1)-E	1	4.98	10.98
Drive Shaft for UPP SCR.K(1)	SCR.K(1) SHAFT	1	0.232	0.51
Scraper Mandrill for 110mm FILLPIPE	SCR.M110-FILL-E	1	1.14	2.5
Mandrill Kit for Legacy Scraper	MDR.K-E	1	3.0	6.61
Mandrill for 63mm Pipe (SDR13.6)	MDR.063-E	1	0.48	1.1
Mandrill for 90mm Pipe (SDR13.6)	MDR.090-E	1	0.77	1.7
Mandrill for 110mm Pipe (SDR13.6)	MDR.110-E	1	1.09	2.4

Clamps



Description	Product Code	Unit	Kg	Lbs.	Material
UPP Pipe Clamp - Straight 32 - 110mm	CLAMP (S)	1	1.98	4.37	Metal
UPP Pipe Clamp - Angled 32 - 110mm	CLAMP (A)	1	2.57	5.67	Metal
Clamp for UPP Fusion Seals 302	302-CLAMP	1	0.61	1.34	Steel
Clamp for UPP Fusion Seals 303	303-CLAMP	1	1.6	3.53	Steel
Clamp for UPP Fusion Seals 304	304-CLAMP	1	1.94	4.28	Steel
Clamp for UPP Fusion Seals 305	305-CLAMP-1	1	1.74	3.84	Steel
Clamp for UPP Fusion Seals 305-125-110	305-EXT-CLAMP	1	2.19	4.83	Steel
Clamp for UPP Fusion Seals 308	308-CLAMP	1	2.22	4.89	Steel

Towing Head for Pipe Threading in Ducts



Description	Product Code	Unit	Kg	Lbs.	Material
Towing Head for UPP Primary Pipe 50mm	TH50	1	0.96	2.12	Aluminium & Steel
Towing Head for UPP Primary Pipe 63mm	TH63	1	1.56	3.44	Aluminium & Steel
Mud Tight Towing Head for UPP SC Pipe 63x50mm	TH63SC	1	1.82	4.01	Aluminium & Steel
Mud Tight Towing Head for UPP SC Pipe 75x63mm	TH75SC	1	2.92	6.44	Aluminium & Steel
Towing Head for UPP UL & EN Pipe 50mm	TH50-SDR8	1	0.62	1.37	Aluminium & Steel
Towing Head for UPP UL & EN Pipe 63mm	TH63SC-SDR8	1	1.49	3.28	Aluminium & Steel

Miscellaneous

Description	Product Code	Unit	Kg	Lbs.	Material
Wooden Mallet	MAL1	1	0.22	0.49	Wood
Pipe Markers - Box of 10 pens	MARKER	1	0.02	0.04	Marker Pen
Flexishaft Driver for band clamps - 8mm	F.DRIVER	1	0.148	0.33	Plastic & metal
Test Port Hole Punch	TP-HP	1	0.2	0.44	Steel
UPP Warning Tape - 100m roll	D/TAPE	100m	0.02/m	0.04/ft	PE/Stainless Steel
Flexible Connector in stainless steel	FLEXCON *	1	--	--	Stainless Steel

* Any diameter, length and termination style. May require up to four week lead time, consult Customer Services for pricing and availability.

NOTE: Franklin Fueling recommend that cleaning/degreasing wipes are purchased locally.

Holesaws



Description	Product Code	Unit	Kg	Lbs.	Material
Mandrill for all Holesaws	MAN1	1	0.22	0.49	Steel
Holesaw 51mm for SB2.C01, SB2-CO1-5, FEB-075-SC, FEB-100-D, FEB-100-SC & 302 Entry Seals	HSCS2	1	0.12	0.26	Steel
Holesaw 83mm for PS3, FEB-150-D, FEB-175-SC, FEB-200-D & FEB-200-SC Entry Seals	HSP3	1	0.25	0.55	Steel
Holesaw 102mm for 303 & FEB-300-R Entry Seals	HS 3	1	0.4	0.88	Steel
Holesaw 105mm for FEB-D-075-1 Entry Seal	HS075	1	0.46	1.01	Steel
Holesaw 140mm for FEB-400-R, FEB-400-F, FEB-D-110-1 & 305 Entry Seals	HS 5	1	0.76	1.68	Steel
Holesaw 160mm for 305-125-110 Entry Seals	HS 6	1	0.87	1.92	Steel
Holesaw 168mm for PS6 Entry Seals	HSP6	1	0.9	1.98	Steel
Holesaw 210mm for 308's Entry Seals	HS 8	1	1.36	3.00	Steel

Seal / Holesaw / Clamp Matrix

Seal Code	Holesaw	Diameter (mm)	Diameter (inches)	Clamp	Clamp Colour
302-040	HSCS2	51	2	302-CLAMP	Orange
303-063-EIF	HS3	102	4	303-CLAMP	Blue
303-075-EIF	HS3	102	4	303-CLAMP	Blue
304-110-050-TP	HS5	140	5½	304-CLAMP	Yellow
304-110-063-TP	HS5	140	5½	304-CLAMP	Yellow
304-110-075-TP	HS5	140	5½	304-CLAMP	Yellow
304-110-090	HS5	140	5½	304-CLAMP	Yellow
304-110-090-TP	HS5	140	5½	304-CLAMP	Yellow
305	HS5	140	5½	305-CLAMP-1	Green
305-R-1	HS5	140	5½	305-CLAMP-1	Green
305-125-110	HS6	160	6 5/16	305-EXT-CLAMP	Red
305-125-110-TP	HS6	160	6 5/16	305-EXT-CLAMP	Red
308	HS8	210	8 ¼	308-CLAMP	Silver
308-R	HS8	210	8 ¼	308-CLAMP	Silver

SB2.C01	HSCS2	51	2
SB2.C01-5	HSCS2	51	2
PS3	HSP3	83	3¼
PS6	HSP6	168	6 5/8

FEB-D-075-1	HS075	105	41/8
FEB-D-110-1	HS5	140	5½
FEB-S-125	HS5	140	5½

Seal Code	Holesaw	Diameter (mm)	Diameter (inches)
FEB-075-SC	HSCS2	51	2
FEB-100-D	HSCS2	51	2
FEB-100-SC	HSCS2	51	2
FEB-150-D	HSP3	83	3½
FEB-175-SC	HSP3	83	3½
FEB-200-D	HSP3	83	3½
FEB-200-SC	HSP3	83	3½
FEB-300-R	HS3	83	3½
FEB-400-R	HS5	140	5½
FEB-400-F	HS5	140	5½



302-CLAMP

303-CLAMP

304-CLAMP



305-CLAMP-1



305-EXT-CLAMP



308-CLAMP

Fuel/Chemical Compatibility Chart to EN14125 (Retail Specific)

Automotive Fuels

- Gasohol (E1 to E10)
- Premium Unleaded Gasoline
- Regular Unleaded Gasoline
- Premium Leaded Gasoline
- Diesel

Bio-Fuels & Blends

- Ethanol 100% (Ethyl alcohol)
- E85 - Ethanol 85% + Unleaded Fuel 15%
- E70 - Ethanol 70% + Unleaded Fuel C 30%
- Ethanol 50% + reference Fuel C 50%
- Ethanol 30% + reference Fuel C 70%
- Ethanol 10% + reference Fuel C 90%
- Biodiesel 10% to 100%

Methanol Mixtures

- Methanol 100%
- Methanol 50% + Reference Fuel C 50%
- Methanol 15% + Reference Fuel C 85%

Test Fuels & Fuel Additives

- UL971 – MV,CT,HB,AM
- ASTM Fuel C 100%
- EN14125 Fuel 1
- EN14125 Fuel 2
- No.2 Fuel Oil
- MTBE 10% + reference Fuel C 90%
- MTBE 15% + reference Fuel C 85%
- Toluene
- AdBlue*

* Requires stainless steel transition fittings.

Aviation & Marine Fuels

- Jet A1 (Avtur)
- JP8 (F-34)
- Methmix
- Avgas
- Kerosene

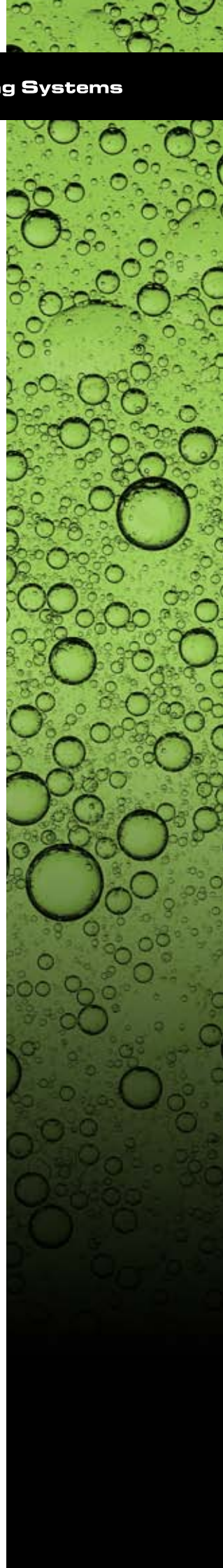

Trenches (Width, Depth & Fall Back)

- It is important to construct proper trenches before laying UPP pipe. Trenches should be wide and deep enough to comfortably allow pipe runs, recommended spacing and backfill materials.
- Recommended burial depth of UPP pipe is a minimum of 300mm (12").
- All trenches should be sloped back towards the storage tanks with a recommended gradient of 1:100.
- Vapour return lines must have a slope of 1:50 (1/4" per foot) and never less than 1:100 (1/8" per ft) back towards the tank farm, unless in-line joints such as elbows are to be used.
- Trench corners should contain a radius suitable for the pipe work.



Bedding

- A recommended 150mm (6") bed of backfill material should be laid underneath the prior to pipe installation and there must never be voids under or around the pipe.
- When laying duct onto a concrete base a 150mm (6") thick bed of compacted sand should be laid on the concrete, below the duct. (Absolute minimum amount of sand should be 50mm (2") of compacted sand).
- All beds should be laid so that the pipe will not dip or sag when it is installed.
- Underground pipe runs may be continuous or have electrofusion welded joints. Any mechanical joints or compression fittings must be inspectionable and located within a containment chamber or sump.
- UPP pipe exceeding 12m (40ft) should be laid in a series of large snake-like curves and not in straight lines. Uncoiled pipe, when laid, will settle in a natural curve.
- Generally any thermal expansion will be accounted for by following our guidelines for spacing, backfilling and ensuring runs are not dead straight.
- Pipes should be separated from each other by at least the diameter of the largest pipe.
- If pipe-runs cross each other they must be separated by at least as much backfill material as the diameter of the largest pipe or protected by using at least 25mm (1") of styrofoam.
- If used above ground, UPP pipe should be protected against mechanical, climatic and fire damage by wrapping it in radiation or thermal shielding tape. Additional supports and anchor points may also be required.
- Contact Franklin Fueling Systems Technical Services for more details concerning above ground installations (see page 86).

Pipe Spacing

- Bed/backfill with pea-shingle, sand or crushed rock.
- Separate pipes by the diameter of the largest pipe in the run.
- For spacers and support use:
 - Expanded polystyrene (Styrofoam).
 - Pipe off-cuts.
 - Timber/block/brick (as temporary measures).
 - Sacks of backfill.

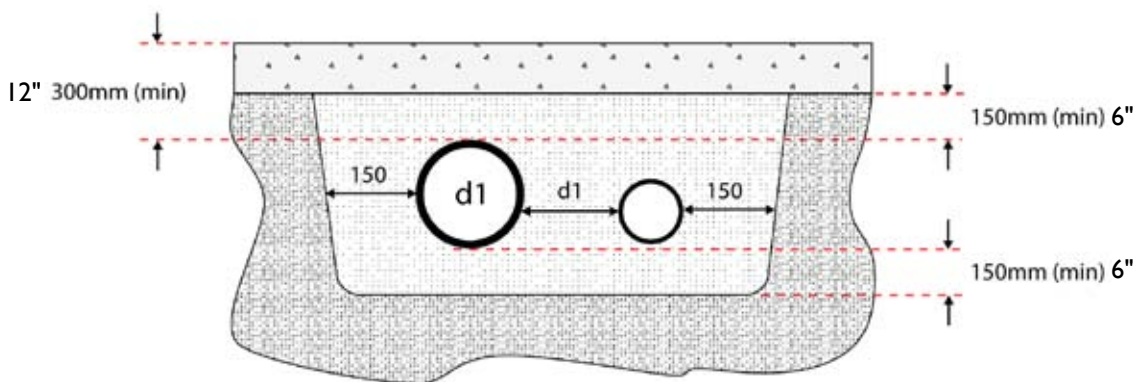

Pressure / Vacuum Rating

When using leak detection equipment it is often necessary to know the interstitial volume of double wall pipes to decide the amount of compressed gas or type of pumped detection unit required. Below are the volumes per metre of UPP pipework.

UPP Extra & EN14125 Pipes	Rated Pressure		Rated Vacuum		Typical Burst Pressure	
	Bar	Psi	Bar	"Hg	Bar	Psi
Primary Pipe	10	145	-0.9	-26.6	40	580
Secondary Pipe	5	58	-0.6	-17.7	20	290
Fill Pipe	6	87	n/a	n/a	30	435
Un-Lined Vent Pipe	10	145	-0.9	-26.6	40	580
Electrical Conduit	10	145	-0.9	-26.6	40	580
Corrugated Duct	n/a					

UL971 Pipes						
Primary Pipe	6.2	90	-0.9	-26.6	40	580
Un-Lined Vent Pipe	4	58	-0.6	-17.7	20	290

Bend Radius

- **Q:** Because UPP is semi-rigid, what Bend Radius is possible during installation?
- **A:** This is largely temperature dependent, but in general you may use these values for single or double wall UPP delivered as coils:

		50 mm	63 mm	90 mm	110 mm
Warm weather	15 x Ø	80 cm	1 m	1.5 m	3 m
Cold weather	25 x Ø	140 cm	1.6 m	2.5 m	4 m
Very Cold weather	35 x Ø	190 cm	2.2 m	3.5 m	5 m

For UPP in 6 m straight lengths welded together and then curved to suit the required layout you can expect:

		50 mm	63 mm	90 mm	110 mm
Warm weather	30 x Ø	1.5 m	2 m	3 m	4 m
Cold weather	60 x Ø	3 m	3 m	5 m	6 m
Very Cold weather	80 x Ø	4 m	4 m	7 m	8 m

Interstitial Volume

When using leak detection equipment it is often necessary to know the interstitial volume of double wall pipes to decide the amount of compressed gas or type of pumped detection unit required. Below are the volumes per metre of UPP pipework.

Double Wall Pipe							
Interstitial Volume	40/32mm	63/50mm	75/63mm	110/90mm	125/110mm	160/90mm	160/110mm
	(1")	(1½")	(2")	(3")	(4")	(3")	(4")
Litres / m	0.24	0.66	0.62	2.15	0.97	10.79	7.64
Cubic Inches / ft	4.40	12.29	11.52	39.93	18.01	200.73	142.12

UL971 Double Wall Pipe				
Interstitial Volume	63/50mm	75/63mm	110/90mm	125/110mm
	(1½")	(2")	(3")	(4")
Litres / m	0.12	0.13	1.41	0.45
Cubic Inches / ft	2.25	2.43	26.21	8.35

Electrofusion Safety

- UPP Welding Units must never be operated in Zone 1 or Zone 0 areas (Hazardous area definitions are from IP Model Code of Safe Practice Part 15 and are available in the APEA Blue Book 2nd Edition).
- UPP Welding units are suitable for use in Zone 2 areas with just the welding leads and fitting being welded positioned in a Zone 1 area.
- Ensure Welding Units are connected to a power supply that meets the requirements detailed in the user manual and are within the requirements of any local authority or regional legislation.
- UPP piping complies with all the requirements imposed by EN14125 concerning electrostatic safety.
- The risk assessment against electrostatic hazard has demonstrated that the use of insulating material such as that used in UPP piping results in a safe choice.
- The safety of UPP systems rely upon the small capacitance and hence the small energy that they can accumulate. This energy, has been demonstrated to be well below the Minimum Ignition Energy or MIE required to ignite petrol or alcohol blended fuel
- Extensive studies simulating fuel flow situations much more severe than what can be found in underground pipework at petrol filling stations have demonstrated that UPP pipe cannot be a source of spark ignition. For this reason UPP pipe can be considered an inherently safe system with respect to the electrostatic risk
- The most important recommendation, common to any type of piping system is to connect safely to ground all metallic components. Metallic components, and more general conductive materials, thanks to their high capacitance can have the potential to store high amount of electrostatic energy (sparks discharge can only be observed over conductive elements).
- All exposed metal parts used in UPP System installations should be adequately grounded to a dedicated earth electrode and brought to a potential equal to that of other metal parts in the close proximity.

All UPP metal transition fittings in the fill box, at the tank top and under the dispenser should be adequately earthed according to local electrical regulations. If in doubt the resistance of grounding should be $\geq 100k\Omega \leq 1M\Omega$. Earthing cables should be plastic covered copper conductors of at least 4mm² cross sectional area and should be connected to an exclusive earth electrode.

Note: The metal fittings at the tank manhole should be at equal potential so additional cables may be required to interconnect the metal fittings.

The drawings show how to ground various types of UPP metal transition fittings:

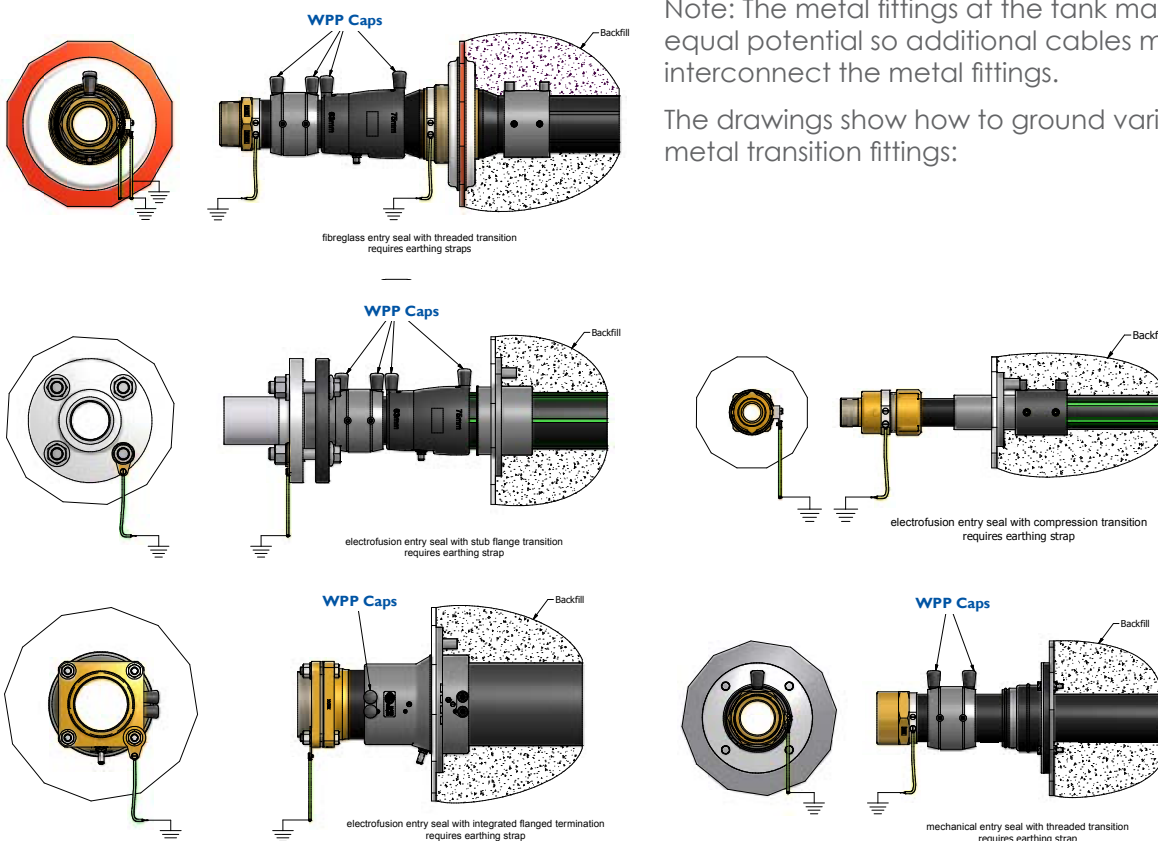

Weld Pin Protection Caps

Paragraph 5.6.2 of EN 14125:2004 requires that the terminal pins of electro-fusion couplers which are not buried in the ground shall be closed with plastic caps. The purpose is to prevent any possible ignition hazard resulting from a static electricity discharge.

Franklin Fueling Systems Ltd has designed a multi-purpose cap to suit all electro-fusion fittings in the UPP System range. The design and materials have been third-party tested and certified as fit-for-purpose.

The caps are only required to be fitted when the coupler is in air (not buried) and when an explosive atmosphere is or may be present, i.e. inside chambers & sumps which are classified as Zone 0, 1 or 2.

- Refer to IP 15 - IP Model Code of Safe Practice Part 15 Area classification code for installations handling flammable fluids, 2nd edition - for a definition of these hazardous areas.

Weld Pin Protection Caps are compatible with all UPP fusion elements such as those for primary and secondary pipework and electro-fusion entry seals. The UPP System Weld Pin Protection Caps have the same fuel resistance as UPP containment products in which they are designed to be used.

1. After executing a fusion weld according to the Franklin Fueling Systems electrofusion assembly process wait for the 20 minutes cooling time.
2. Press one cap firmly over each shroud surrounding the pin.
3. Tap cap with light hammer to ensure it is fully seated.
4. Inspect all of the chamber / sump area to ensure that all unburied electro-fusion fittings have been securely fitted with Weld Pin Protection Caps.

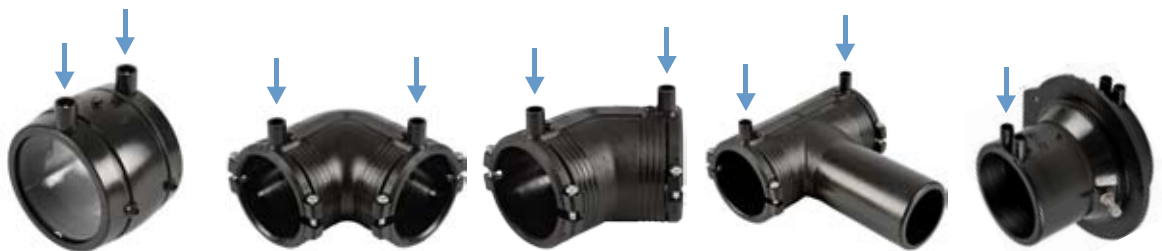

If you wish to contact us about any of our products or services please contact the nearest Franklin Fueling Systems office.

For a list of local contacts please visit franklinfueling.com for more information.

US and Canada

Franklin Fueling Systems
3760 Marsh Rd.
Madison, Wisconsin
53718, USA
T: +1 800 225 9787
F: +1 608 838 6433

Brazil

Franklin Fueling Sistemas de Combustíveis Ltda
Rua Kanebo, 175, Modulo D1,
Conjunto 2 Distrito Industrial,
Jundiai, Sao Paulo, Brazil, 13213-090
T: +55 11 3395 0606

Europe

Franklin Fueling Systems GmbH
Rudolf-Diesel-Str. 20,
54516, Wittlich,
Germany
T: +49 6571 105 380
F: +49 6571 105 510

France

Franklin Fueling Systems France Sarl
129 Avenue du Général de Gaulle,
F-91170 Viry-Chatillon,
France
T: +33 1 69 21 41 41
F: +33 1 69 21 42 42

UK

Franklin Fueling Systems Limited
Olympus Close, Whitehouse Industrial Estate,
Ipswich, Suffolk,
IP1 5LN, UK
T: +44 (0)1473 243 300
F: +44 (0)1473 243 301

China

Franklin Fueling Systems (Beijing) Co., Ltd
A802, ChaoWaiMEN Center, No. 26 Chaowai Street,
Chaoyang District,
Beijing 100020, China
T: +86 10 8565 4566
F: +86 10 8565 4766

Australia

Franklin Fueling Systems Australia
21 Aristoc Road - PO Box 47
Glen Waverley, Vic 3150
Australia
T: +61 3 9550 1874
F: +61 3 95 61 94 77

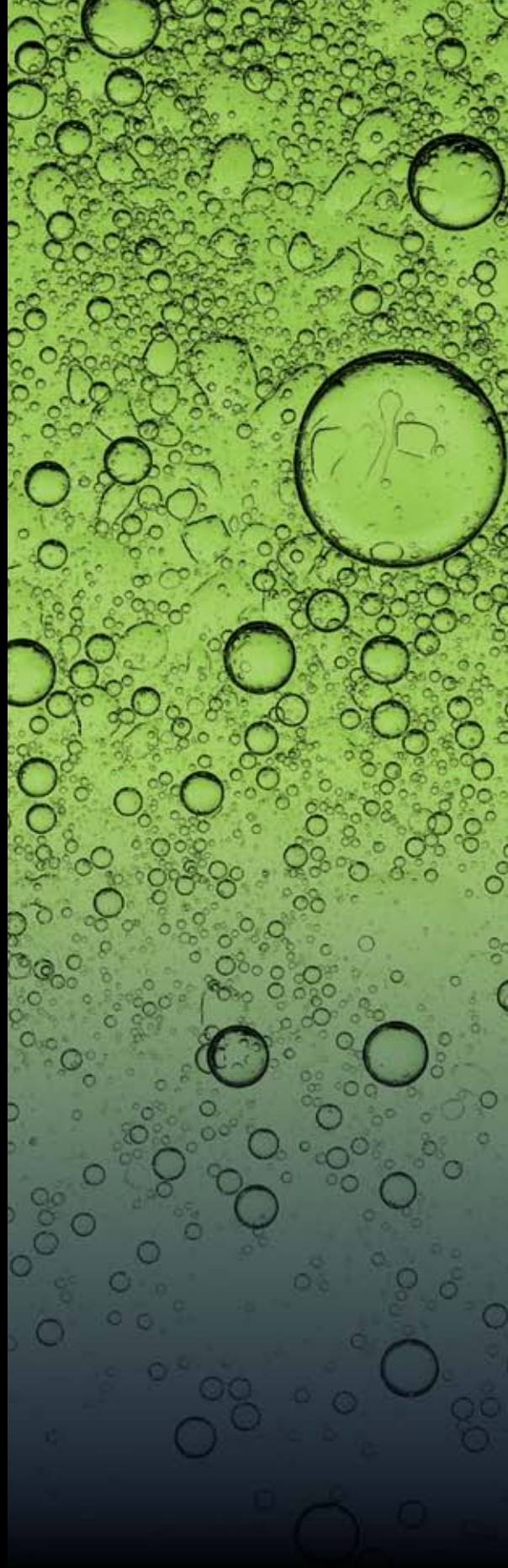

Franklin Fueling Systems

franklinfueling.com

Franklin Fueling Systems GmbH
Rudolf-Diesel-Str. 20, 54516 Wittlich, Germany
Tel: +49-6571-105-380 • Fax: +49-6571-105-510
US/Can: +1 800 225 9787 • Mex: 001 800 738 7610
UK: +44 (0)1473 243300 • FR: +33 (0) 1 69 21 41 41 • CN: +86 10 8565 4566



FFS-0158 UPP-SSH 05-12

Global Product Catalogue